

GROUND VIBRATION FROM RIGID FOUNDATION BY BEM-TLM

Badreddine Sbartai* and Ahmed Boumekik**

*Department of Civil Engineering

University of Skikda, 21000 Skikda, Algeria

**Department of Civil Engineering

University of Constantine, 25000 Constantine, Algeria

ABSTRACT

This study investigates a prediction model for free-field response in the vicinity of a vibrating foundation. The model is based on a mathematical description of physical phenomena that occur when the massless machine foundation system is excited by a harmonic vertical force. The foundation has a square and rigid shape and is assumed to be placed on the surface of visco-elastic soil overlying the bedrock. Vertical displacements of both the foundation and the surrounding soil are obtained by solving the wave's equation, while considering the conditions of the dynamic soil-foundation interaction. The solution of this equation is formulated in the frequency-domain Boundary Element Method (BEM). In this paper the Thin Layer Method (TLM) is used to calculate the Green's functions for each element. By this approach, the amplitudes of the soil in the vicinity of a vibrating foundation may be obtained under the effect of various parameters.

KEYWORDS: Wave Propagation, BEM, TLM, Soil-Structure Interaction

INTRODUCTION

The major problem that must be addressed during the construction of particular types of structures, such as conventional and nuclear power plants, chemical factories, liquid natural gas tanks, etc., concerns the rigorous safety conditions that must be established to avoid damage caused by various types of excitations to which these structures can be subjected. The strong interest in this problem is not only because of the constant increase in the quality and stability requirements of the constructions in the vicinity of these structures but also because of the need to protect sensitive material. The analysis of the response of these structures and that of the neighbouring soil is a wave-propagation problem that leads to consideration of the soil-structure interaction. To face these challenges, research in this field has been oriented toward numerical methods because the classical analytical methods, which are generally based on restrictive assumptions about the geometry of the foundation and the elastic properties of the soil, are not adapted to treat the problems of such great complexity. Also, the study of soil-structure interaction remains important and justifies the particular interest that many researchers have shown in it up to the present day.

Many studies have been performed in earthquake engineering with regard to wave propagation in ground. In a pioneering work, Lamb (1904) investigated the response of an isotropic, homogeneous, elastic half-space to various loads and established models for two- and three-dimensional wave propagation. Among the many analytical-numerical and numerical works on wave propagation in layered media, with constant material properties in every layer, one can mention the classic text of Reissner (1936) as well as the works of Ewing et al. (1957), Thomson (1950), Haskell (1953), Gupta (1966), and Richart et al. (1970). Later, Takahashi (1985, 1986) studied the response of a structure on visco-elastic half-space to ground-transmitted vibrations caused by a harmonic line source on the surface of the half-space.

The finite-element method (FEM) has been adopted to solve wave-propagation problems with a wide range of soil properties. This method, although attractive, is computationally expensive, because it requires the discretization of both the infinite medium and the foundation. Because of this, its use is limited to two-dimensional problems, such as those addressed by Waas (1972), and Chang-Liang (1974). Using this method, Kausel et al. (1975) analyzed the behaviour of rigid foundations resting on or embedded in a stratum over bedrock. However, Lysmer and Kuhlemeyer (1969) analyzed the behaviour of foundations resting on or embedded in semi-infinite soil by using an absorbing boundary.

More recently, very efficient methods have been developed to treat wave-propagation or diffraction problems, most notably the boundary-element method (BEM). In this approach, field displacement has been formulated by Beskos (1987) as an integral equation in terms of Green's functions. Also, using this method in conjunction with a constant element and Green's function for half-space, Apsel and Luco (1987) calculated the impedance functions for foundations embedded in layered media, and Dominguez (1978) studied the case of a rigid rectangular foundation placed on or embedded in semi-infinite soil. However, Ahmad and Rupani (1999) studied the horizontal impedance of square foundations resting on or embedded in two-layer soil deposits using isoparametric boundary element. In contrast, Beskos et al. (1986) studied the problem of structural isolation from ground-transmitted vibrations by open or infilled orthogonal trenches under the condition of plane strain.

Wong and Luco (1985) developed a method that permits the evaluation of impedance functions for square rigid foundations resting on a visco-elastic layer overlying a visco-elastic half-space. This method is based on dividing the contact area between the foundation and the soil into a number of sub-regions and on assuming that the contact tractions within each area are uniform but of unknown amplitudes.

In addition, Waas (1972) developed a semi-discrete analytical method to model the far field with homogenous boundary conditions for two-dimensional and axi-symmetric problems. With the aid of the thin-layer theory, Kausel and Peek (1982) obtained Green's functions for multi-layered soils. This semi-discrete analytical model has been then combined with the BEM of the near field to solve the soil-structure interaction problems in layered media. Using this approach, Boumekik (1985) and Boumekik et al. (1984) studied the 3-D problem of embedded foundations on layered substrata.

Recently, Wolf (2002) developed the novel scaled-boundary, finite-element method, which combines the advantages of the BEM and the FEM to calculate the dynamic stiffness of the embedded foundation and the displacements in the neighbouring soil.

The principal aim of this article is the calculation of the displacements of a foundation, and the soil that surrounds it, at a certain distance caused by a vibrating machine, using a coupled numerical method (BEM, and the thin-layer method or TLM) in the frequency domain in conjunction with the Kausel-Peek Green's function (Kausel and Peek, 1982) for a layered stratum and constant element. The vertical displacement of the foundation is obtained by the determination of its vertical impedance function, for which only the soil-foundation interface is discretized, and the results are validated via comparison with the results of Dominguez (1978), Wong and Luco (1978, 1985), and Mylonakis et al. (2006). However, calculation of the vertical soil displacements near the foundation is carried out by means of a mathematical model developed in this study by the combination of BEM and TLM. This model represents the product of compatible tractions at the soil-foundation interface and the flexibility matrix of the neighbouring soil. The principal advantage of this model is that it allows the calculation of the attenuation of vertical displacements near the foundation for several types of soils and foundations.

MODELS AND EQUATIONS

1. Physical Model and Basic Equations

The source of vibrations is assumed to be a square, massless foundation (see Figure 1), with length B_x and width B_y , and subjected to a unit vertical harmonic force $P_z e^{i\omega t}$. The foundation is placed on a surface of visco-elastic soil characterized by its shear modulus G_1 , shear wave velocity C_{s1} , mass density ρ_1 , Poisson's ratio ν_1 , and hysteretic damping coefficient β_1 . This soil layer of depth H is limited by a bedrock characterized by its shear modulus G_2 , shear wave velocity C_{s2} , mass density ρ_2 , Poisson's ratio ν_2 , and hysteretic damping coefficient β_2 . In the following equations, the term $e^{i\omega t}$ will be implicit for displacements and forces.

The (complex) displacement of point A at the free surface, defined by its abscissa $x = d/2B_x$ from the foundation edge, is obtained from the wave equation

$$(C_p^2 - C_s^2)u_{j,ij} + C_s^2 u_{i,ji} + \omega^2 u_i = 0 \quad (1)$$

where u_i is the x -component of the harmonic displacement amplitude vector; $u_{j,ij}$ is the partial derivative of u_j with respect to x - and y -axes; $u_{i,ij}$ is the second partial derivative of u_i with respect to y -axis; C_s and C_p are the shear (S)- and compression (P)-wave velocities; and ω is the angular frequency of excitation.

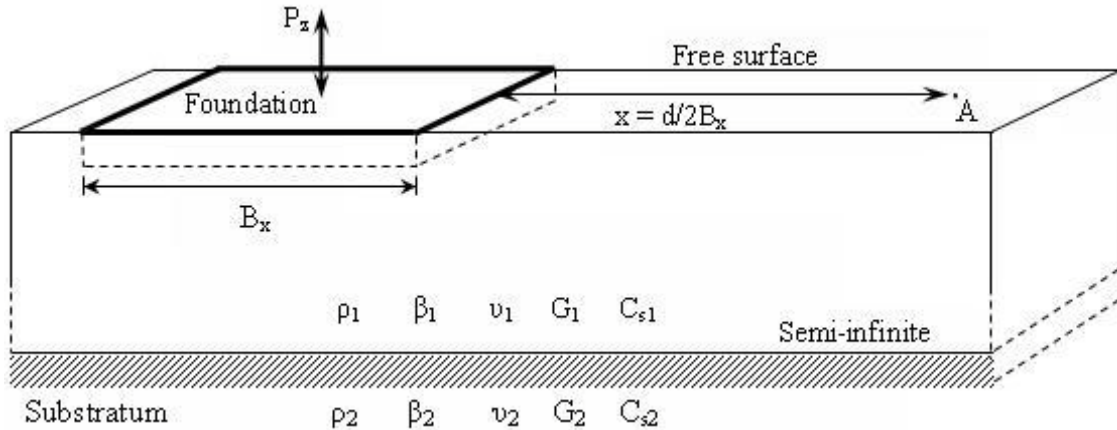

Fig. 1 The geometry of the model

The solution of Equation (1) can be obtained in form of the following boundary integral equation in frequency domain:

$$u_j(x, \omega) = \int_s G_{ij}(x, \xi, \omega) t_i(\xi, \omega) ds(\xi) \tag{2}$$

Here, G_{ij} represents the Green's function tensor, and t_j the surface traction.

Equation (2) remains difficult to solve as long as the domain is a continuum. However, if the domain is discretized in an appropriate form, Equation (2) can be algebraically evaluated for each element. In this approach, the discretization principle of the soil mass is represented in Figure 2. It is based on two types of discretization, one horizontal and other vertical. The horizontal discretization consists of subdividing any horizontal section of the soil mass into square elements. The average displacement of the element is replaced by its centre displacement, for which the distribution of the constraints is supposed to be uniform.

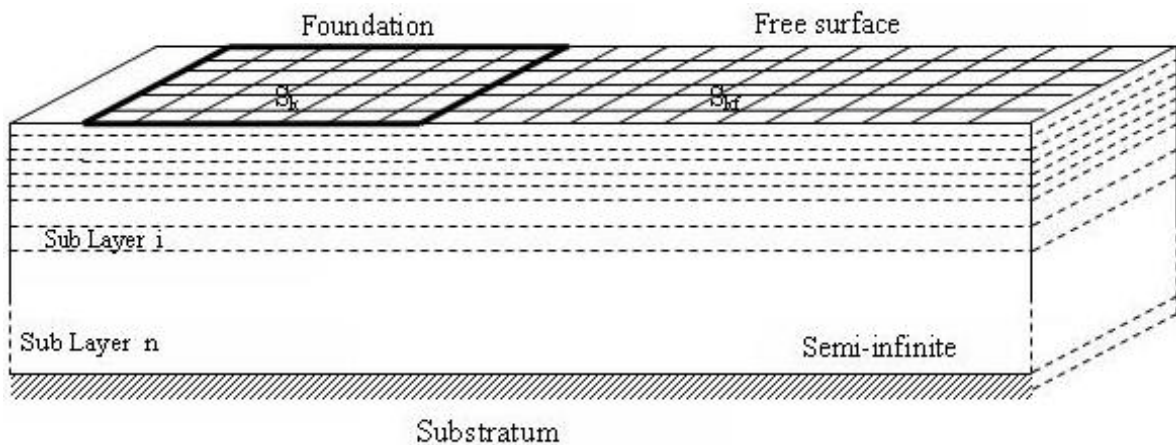

Fig. 2 The discretization of the model

The vertical discretization consists of subdividing the soil mass into sub-layers, which have a rather low thickness compared with the Rayleigh wavelength ($= \lambda/10$), in order to linearize the displacement from one sub-layer to the next. The interface of soil and foundation is horizontally subdivided into N_f

quadrilateral elements, on which uniform forces are applied. The free surface where the displacements are investigated is subdivided into N_h quadrilateral elements.

In the discretized model, Equation (2) is expressed in the algebraic form as follows:

$$u_j = \sum_{i=1}^{\text{NRT}} \int_s G_{ij} t_i ds \quad (3)$$

Here, NRT represents the total number of elements, which discretize the free surface and the interface between the soil and the foundation.

2. Determination of Green's Functions by TLM

In this work, body B is a layered stratum resting on a substratum base with n horizontal layer interfaces defined by $z = z_1, z_2, \dots, z_N$ and with layer j defined by $z_n < z < z_{n+1}$, as shown in Figure 3. The medium of each n th layer of h_n thickness is assumed to be homogeneous, isotropic, and linearly elastic. For this body, the Green's function in frequency domain is obtained with the aid of the Thin Layer Method (TLM).

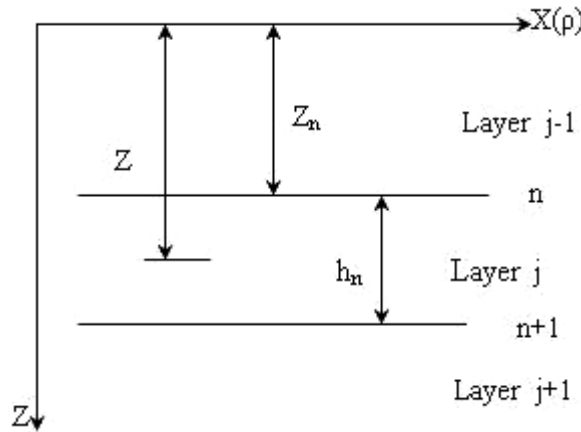

Fig. 3 Geometry of layered stratum B

Actually, the Green's function for a layered stratum is obtained by an inversion of the thin-layer stiffness matrix through the spectral decomposition procedure of Kausel and Peek (1982). The advantage of the thin-layer stiffness matrix technique over the classical Haskell-Thomson transfer matrix technique for finite layers (Haskell, 1953; Thomson, 1950) and the finite-layer stiffness matrix technique of Kausel and Roesset (1981) is that the transcendental functions in the layered stiffness matrix are linearized. According to the thin-layer theory of Lysmer and Waas (1972) and Lysmer et al. (1981), the thickness of each layer is chosen to be sufficiently small (less than 1/10 of the Rayleigh wavelength), such that the displacements in this layer can be assumed to vary linearly with depth and then remain continuous in the x -direction. Thus the Fourier transform of the displacements with respect to the x -domain can be represented by a linear interpolation of the discrete nodal displacements at the n th-layer interfaces as

$$\begin{aligned} U^{(n)}(z) &= (1-\eta)U^n + \eta U^{n+1} \\ V^{(n)}(z) &= (1-\eta)V^n + \eta V^{n+1} \\ W^{(n)}(z) &= (1-\eta)W^n + \eta W^{n+1} \end{aligned} \quad (4)$$

where $\eta = (z - z_n)/h_n$ with $0 \leq \eta \leq 1$, and $U^{(n)}$, $V^{(n)}$, and $W^{(n)}$ are the transformed displacements along the x -, y -, and z -directions as functions of z in the layer j , and U^n , V^n , and W^n are their nodal values at the layer interface $z = z_n$.

Thus, the Green's frequency-domain displacement tensor, after inversion of the Fourier transform, can finally take the form of Kausel and Peek (1982):

$$G_{ij}^{mn} = \sum_{l=1}^{2N} \frac{a_{\alpha\beta} \phi_i^{ml} \phi_j^{nl}}{k^2 - k_l^2} \quad (5)$$

where $a_{\alpha\beta} = 1$ if $\alpha = \beta$, and $a_{\alpha\beta} = k / k_l$ if $\alpha \neq \beta$; indices i and j refer to the x -, y -, and z -axes; k and k_l are wave numbers; m represents the interface where the load is applied; n represents the interface where the Green's functions are calculated; ϕ_i^{ml} denotes the eigenvector component in the i th direction at the m th layer interface of the l th wave mode; and ϕ_j^{nl} denotes the eigenvector component in the j th direction at the n th layer interface of the l th wave mode.

The Green's functions thus obtained are complex and constitute the starting point for the determination of the flexibility matrix of an arbitrary soil volume. However, taking into account the geometry of the foundation, we adopt a system of Cartesian coordinates. The Green's functions thus obtained, in fact, constitute the terms of the flexibility matrix of the soil, $[F_s]$. The determination of this flexibility matrix allows us, in turn, to obtain the impedance functions of one or several foundations. For more details about the computation of the above Green's functions, the reader may refer to the works of Boumekik (1985) and Kausel and Peek (1982).

Visco-elastic soil behavior can be easily introduced in the present formulation by simply replacing the elastic constants λ and G with their complex values,

$$\lambda^* = \lambda(1 + 2i\beta) \quad (6)$$

$$G^* = G(1 + 2i\beta) \quad (7)$$

where β is the constant hysteretic damping coefficient.

3. Mathematical Model

The knowledge of Green's functions allows obtaining harmonic displacements resulting from the discretized domain by successive application of unit forces on all the interface elements, and thus flexibility matrix is constructed. In the particular case of a symmetric foundation (i.e., rectangular, square, ...), it is possible to uncouple the flexibility matrix along the two principal axes (x and y) to reduce its dimension. This matrix is essential to calculate the displacements of the soil. In this work, we look for the vertical displacements through the following relation:

$$\{u_z\} = [F_s] \{t_z\} \quad (8)$$

where $[F_s] = \{G_{ij}^{mn}\}$ represents the flexibility matrix of the discretized domain, which includes the terms of Green's functions; $\{u_z\}$ represents the vertical harmonic displacements; and $\{t_z\}$ represents the surface tractions. In fact, this relation constitutes the formulated solution, in terms of the displacements of Equation (2) that essentially requires a discretized domain. If u_{zf} and u_{zh} are respectively the harmonic displacements under the foundation and in its neighbourhood, Equation (8) can be explicitly written as

$$\begin{Bmatrix} u_{zf} \\ u_{zh} \end{Bmatrix} = \begin{bmatrix} F_f \\ F_h \end{bmatrix} \{t_z\} \quad (9)$$

This expression permits us to obtain displacement forces under the foundation,

$$\{u_{zf}\} = [F_f] \{t_z\} \quad (10)$$

and displacement forces in the vicinity of the foundation,

$$\{u_{zh}\} = [F_h] \{t_z\} \quad (11)$$

with $[F_f]$ denoting the complex flexibility matrix of discretized soil under the foundation; $[F_h]$ denoting the complex flexibility matrix outside the foundation; $\{u_{zf}\}$ denoting the soil displacement vector under the foundation; $\{u_{zh}\}$ denoting the soil displacements outside the foundation; and $\{t_z\}$ denoting the traction forces on any element at the soil-foundation interface.

When the foundation is in place, all elements must move as a rigid body. This condition is expressed by

$$\{u_{xf}\} = [R]\{D_z\} \quad (12)$$

where $\{D_z\}$ denotes the vertical displacements of the foundation; and $[R]$ represents the transformation matrix of size $N_f \times 1$.

The dynamic equilibrium between the traction forces on each element and the exterior force is expressed by

$$\{P_z\} = [R]^T \{t_z\} \quad (13)$$

where $\{P_z\}$ is the vertical exterior force.

From Equations (10) and (12), the compatible forces to apply on the elements are

$$\{t_z\} = [F_f]^{-1} [R]\{D_z\} \quad (14)$$

Combining Equations (11)–(14), the displacements of the foundation and on the free surface are obtained as

$$\{D_z\} = [K_z(\omega)]\{P_z\} \quad (15)$$

where

$$[K_z(\omega)] = [R]^T [F_f]^{-1} \{R\} \quad (16)$$

is the vertical impedance function of the foundation. It is customary to introduce the dimensionless frequency $a_0 = \omega B_x / C_s$ at the soil-foundation interface, to scale $K_z(\omega)$ with static-stiffness coefficient K_{st} ($= K_z(\omega = 0)$), and to apply the following decomposition:

$$[K_z(\omega)] = [K_{st}(k(a_0) + ia_0c(a_0))](1 + 2i\beta) \quad (17)$$

with $k(a_0)$ denoting the dimensionless spring coefficient; c denoting the dimensionless damping coefficient; β denoting the constant hysteretic damping coefficient; and

$$\{u_{zh}\} = [F_h][F_f]^{-1}\{R\}\{D_z\} \quad (18)$$

In the following, this relation is used to analyze the surface vibration in the vicinity of the harmonic machine foundation load.

RESULTS

The accuracy of the above-described BEM-TLM formulation for the computation of the ground vibration due to a machine foundation is tested in this section through comparisons with other methods.

Let us consider initially the comparison involving the method of Dominguez (1978), relating to a rectangular surface and an embedded foundation, and then that of Wong and Luco (1978) relating only to a surface foundation. The foundation, which is rigid, massless, and rectangular with sides $2B_x$ and $2B_y$, is placed on a semi-infinite soil with Poisson's ratio $\nu = 1/3$ (see Figure 4). Figures 5(a) and 5(b) show the real part K_z/K_{st} and imaginary part C_z/K_{st} of the vertical impedances as functions of the dimensionless frequency $a_0 = \omega B_x / C_s$. It may be observed that the results of this study, for both surface and embedded cases, match those of Dominguez (1978), with the differences being negligible. Figure 5(c) shows the real part K_z and imaginary part C_z/a_0 of the vertical impedances as functions of the dimensionless frequency. It may be observed that the results of this study have an excellent agreement with those of Wong and Luco (1978).

The second comparison concerns the case of a square foundation resting on a visco-elastic layer overlying a visco-elastic semi-infinite soil. In Figure 6, the effect of the relative ratio of layer thickness is

examined for a given frequency, with H/B_x taken as 1 and 2. The soil is characterised by wave velocities ratio $C_{s1}/C_{s2} = 0.8$ and Poisson's ratios $\nu_1 = \nu_2 = 0.33$; the density ratio ρ_2/ρ_1 is taken as 1.13; and the material damping constants in the layer and the semi-infinite soil are taken to be as $\beta_1 = 0.05$ and $\beta_2 = 0.03$. It may be observed that the results of this study have an excellent agreement with those of Wong and Luco (1985).

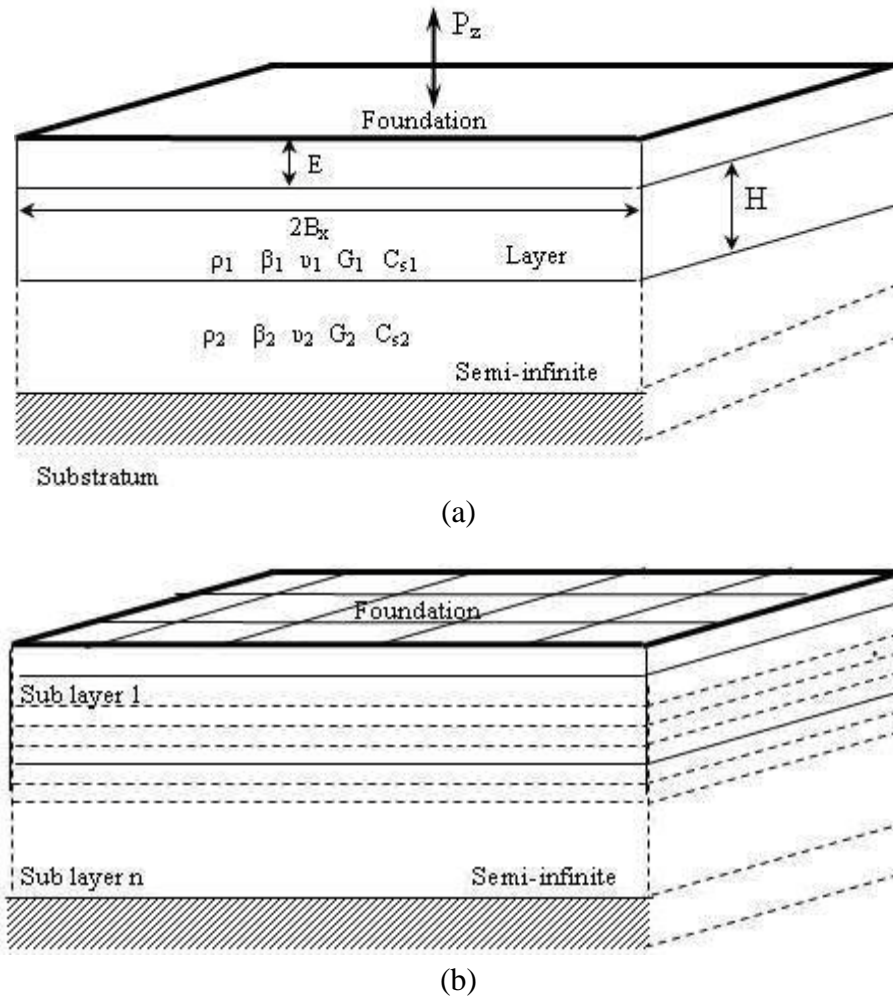

Fig. 4 Model for validation: (a) geometry, (b) discretization

The third comparison concerns the case of a rectangular foundation placed on homogeneous soil layer overlying the bedrock. In Figure 7(a), the effect of the relative length of the foundation is examined for a given frequency, with B_x/B_y taken as 1 and 2. The soil is characterised by the relative depth $H/b = 4$ and Poisson's ratio $\nu = 0.3$. In Figure 7(b), the effect of the relative depth of soil is examined for a square foundation (i.e., $B_x/B_y = 1$) resting on a soil layer with Poisson's ratio $\nu = 0.3$, with H/B_x taken as 2 and 4. For the two cases, it may be observed that these results have an excellent agreement with those of Mylonakis et al. (2006).

Figure 8 shows the comparison between the displacements of free surface in the vicinity of a surface machine foundation for the static case and those obtained by the analytical Boussinesq-Cerruti method that has been generalised for a dynamic case by Lamb (1904). In this method the vertical displacement due to unit vertical contact pressure uniformly distributed over a rectangular area is given by the following equation:

$$u_z = \frac{(1-\nu^2)F}{\pi EB_x} \tag{19}$$

where ν denotes Poisson's ratio; E denotes Young's modulus; and F is a coefficient that varies only with the ratio d/B_x and foundation dimensions, and is given by the Król table (Król, 1971; Cheng, 1977).

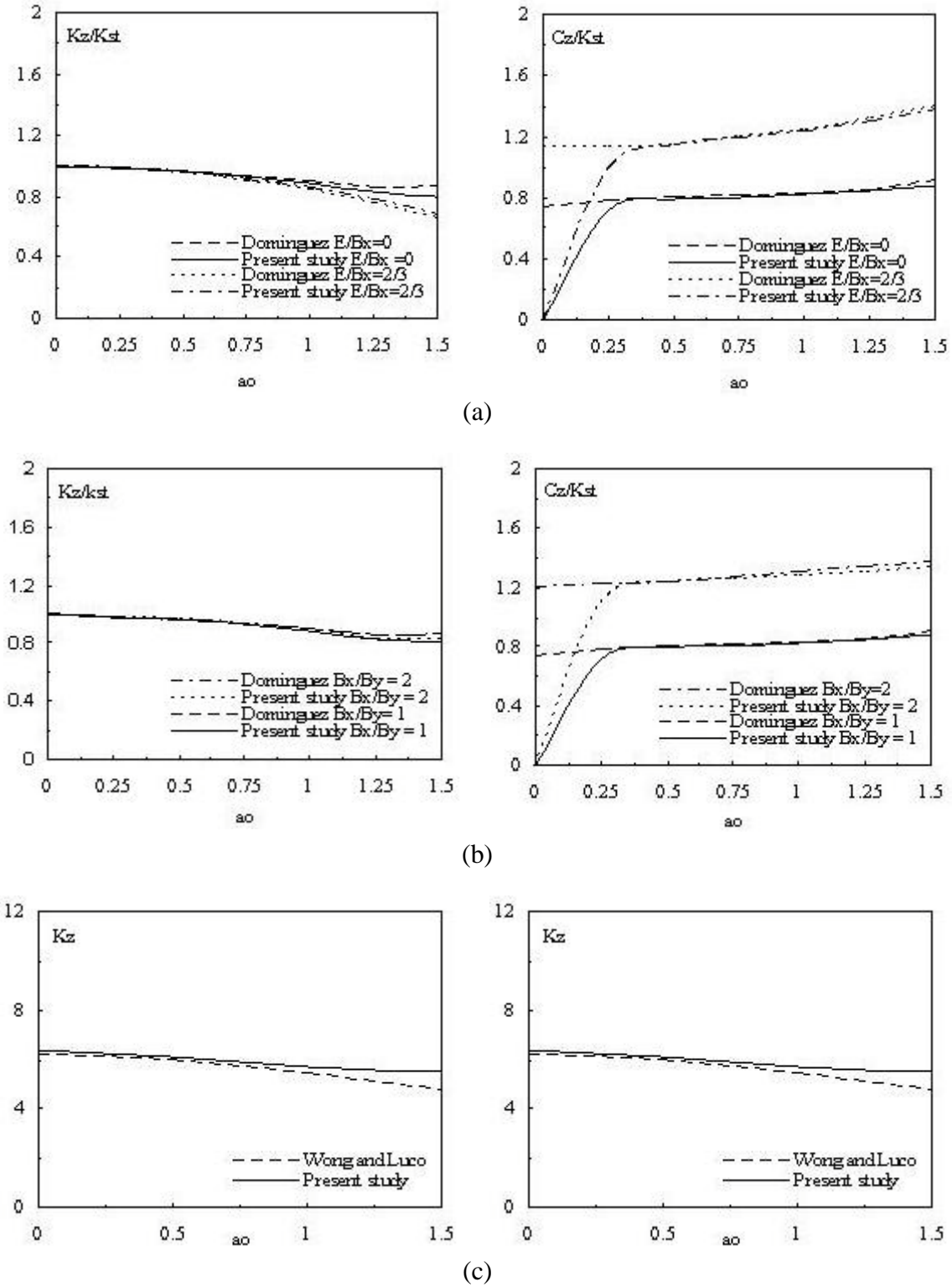

Fig. 5 Validation of vertical impedance functions of rigid foundation on semi-infinite soil: (a) square surface and embedded foundation; (b) square and rectangular foundation; (c) square surface foundation

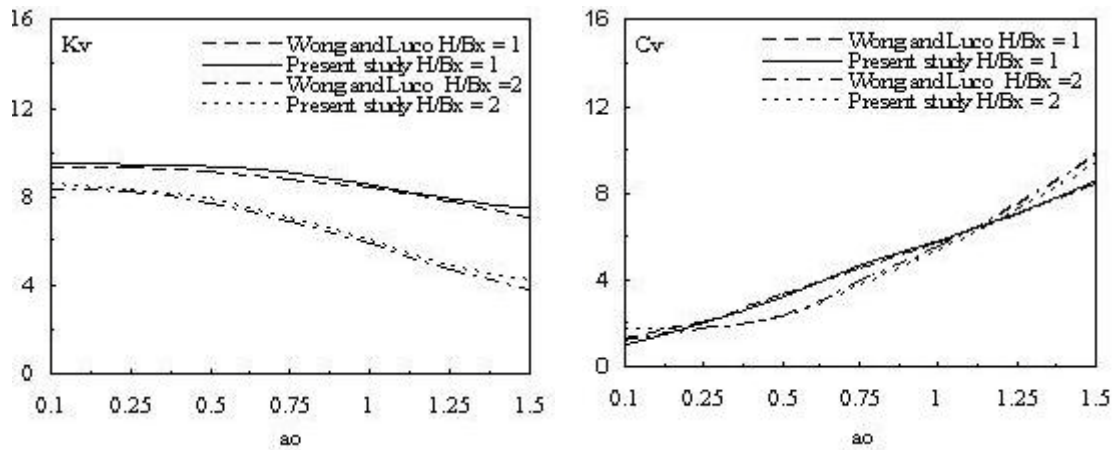

Fig. 6 Validation of vertical impedance function of square rigid foundation resting on layer overlying semi-infinite soil for varying relative ratio of layer thickness ($H/B_x = 1, 2$), with $C_{s1}/C_{s2} = 0.8$ and $\rho_2/\rho_1 = 1.13$ (uniform layer case)

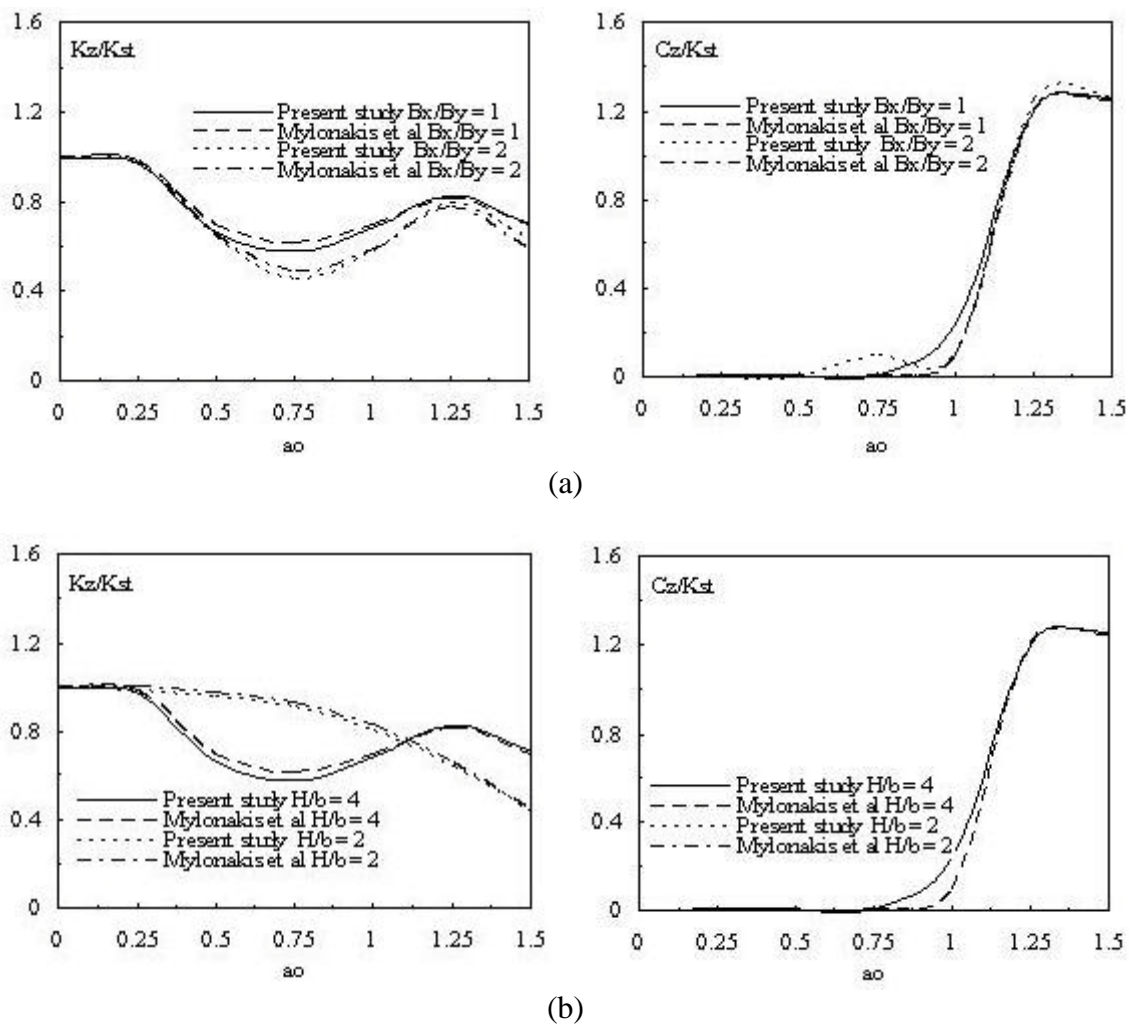

Fig. 7 Validation of vertical impedance function of rigid foundation on soil layer over bedrock: (a) rectangular surface foundation for varying relative length, with $H/B_x = 4$; (b) square surface foundation for varying depths of the substratum

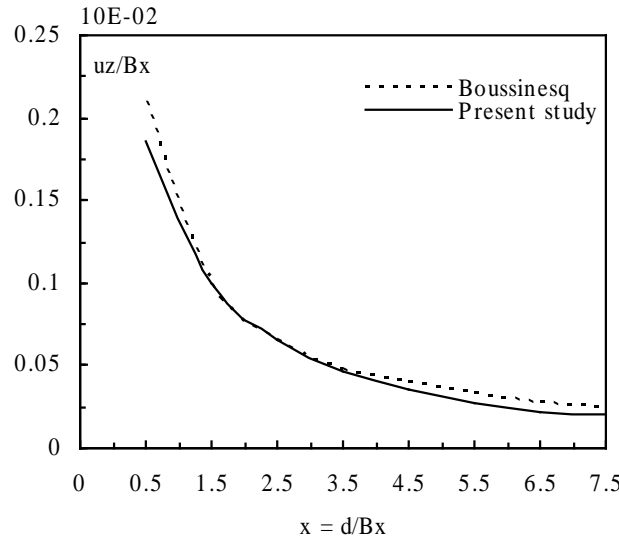

Fig. 8 Validation for static vertical displacement along the free surface

Figure 8 provides the dimensionless, vertical surface amplitude u_z / B_x as a function of the relative distance d / B_x , where B_x is the width of the foundation, and $\rho = 1$, $G = 1$, $E = 1.37$ and $\nu = 0.333$ are the properties of the soil. The comparison of these results with the analytical results clearly shows very good agreement between the two methods.

The dimensionless vertical displacement near the foundation (i.e., $\text{Re} u_z / 2B_x$ and $\text{Im} u_z / 2B_x$) is studied for different cases of the dimensionless frequency (i.e., $a_0 = 0, 1, 2, 3, 4$) at a relative distance of $x = d / 2B_x = 9.25$. In this application, the analysis concerns the case of a square foundation placed at the surface of a visco-elastic, semi-infinite soil, and the considered foundation is subjected to unit vertical force (i.e., $P_z = 1$) for different values of dimensionless frequency $a_0 = \omega B_x / 2C_s$. The free surface and the soil-foundation interface are discretized into 20 quadrilateral constant elements, and the soil is characterised by $\rho = 1$, $G = 1$, $\nu = 0.333$, and $\beta = 0.05$. By varying the excitation frequency, following observations are made for the real displacements (see Figure 9):

1. There is an important variation in the magnitude of the displacement at close distances ($x \leq 3$). The real vertical displacement decreases, when the excitation frequency is increased.
2. The real vertical displacement decreases, when the relative distance is increased.
3. There is a remarkable shift in the resonant frequencies toward the lower frequencies.
4. There is a variation in the resonance peaks governed by the Rayleigh wave.

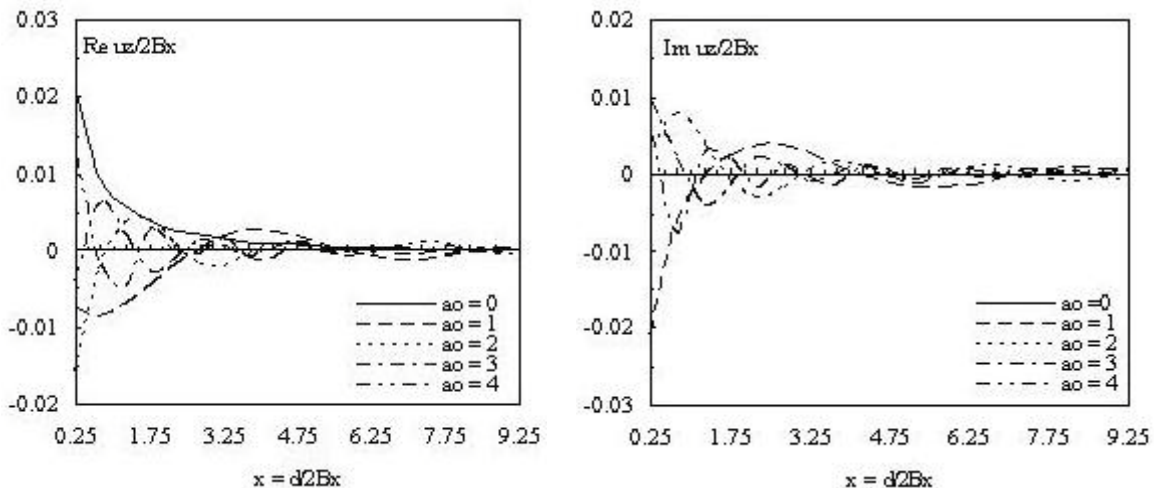

Fig. 9 Amplitude of vertical displacement along the free surface

The behaviour of the imaginary displacements is similar to that described above for the real displacements.

Figure 10 shows the effect of the relative depth of the substratum, for a relative distance along the free surface, with $H/2B_x$ taken as 2, 4, and that for the semi-infinite case, respectively for $a_0 = 0, 1, 2, 3,$ and 4. The soil and the substratum are characterised, respectively, by $\rho_1 = 1, G_1 = 1, C_1 = 1, \nu_1 = 0.333, \beta_1 = 0.05,$ and $\rho_2 = 1, G_2 = 1, C_2 = 1, \nu_2 = 0.333, \beta_2 = 0.01.$ While varying the substratum depth, it may be noted that the variation in the vertical direction is governed by the Rayleigh wave velocity $C_R,$ with $C_R/C_S = 0.94$ for $\nu = 0.333.$ This is clearly visible in Figure 10. The resulting wavelength $\lambda (= C_R/(a_0/2\pi))$ is equal to 2.95, 1.476, 0.8, 0.74 for $a_0 = 1, 2, 3, 4,$ respectively.

For both the low frequencies and the static case (i.e., $a_0 = 0$), a quick decreasing of the soil displacement without oscillations may be noted when the substratum approaches the free surface. We also note that the vertical displacement decreases when the relative distance is increased.

In Figure 11, the effect of the wave-velocity ratio of a semi-infinite soil versus relative distance is examined, for a given frequency, with C_{s1}/C_{s2} taken as 0.2, 0.4, and 1. In varying the wave-velocity ratio, following observations may be made:

1. There is a clear amplification of the vertical displacements, when the wave-velocity ratio is decreased. This can be explained by the fact that the surface waves are imprisoned in the soft layer (i.e., $C_{s1}/C_{s2} = 0.2$).
2. The vertical displacement decreases when the relative distance is increased.

CONCLUSIONS

In this study, the vertical displacements transmitted at the free surface by a vibrating rigid foundation, resting on homogeneous visco-elastic soil and subjected to vertical harmonic external excitation, have been calculated (the case of heterogeneous soil will be treated in the second part of this study). The solution has been formulated by employing the frequency-domain boundary-element method (BEM) in conjunction with the Kausel-Peek Green's function for a layered stratum, along with a quadrilateral constant element determined using the thin-layer method (TLM). The study shows well the great importance of the wave-propagation problem in the vicinity of a machine foundation, which proves to be more complicated than the static case of the Boussinesq problem. On the basis of the results presented in this paper, the following conclusions can be stated:

1. The proposed BEM-TLM formulation provides a very good tool for studying wave propagation and soil-structure interaction problems in multilayered soils.
2. The problem of soil-structure interaction has been treated in a highly accurate and efficient way by calculating the vertical impedance function of a rigid foundation resting on a semi-infinite soil or soil layer. The case of an embedded and arbitrary-geometry foundation has also been treated.
3. Parametric studies have been conducted to assess the effects of the various substratum depths, frequencies, and wave-velocity ratios on the ground-vibration response and to provide some design guidelines to the engineers.
4. The vertical ground vibration is governed by the Rayleigh wave velocity.
5. The effect of the low frequencies on the vertical displacements is more pronounced than that of the higher frequencies for a semi-infinite soil case.
6. For a substratum with little depth, the attenuation of the ground vibrations is more important in the low frequencies than in the high ones (for the propagation of waves without oscillations).
7. A higher variation has been observed in the vertical ground displacements for the soft, semi-infinite soils than for the stiff ones.
8. The soil vibrations are less pronounced, when the relative distance increases (for a visco-elastic soil). It is thus recommended to take into account all of these phenomena in the study of any structure placed in the vicinity of a machine foundation because the transmitted waves represent a critical factor that influences the behaviour of the structure and the amount of damage that can be caused to it.

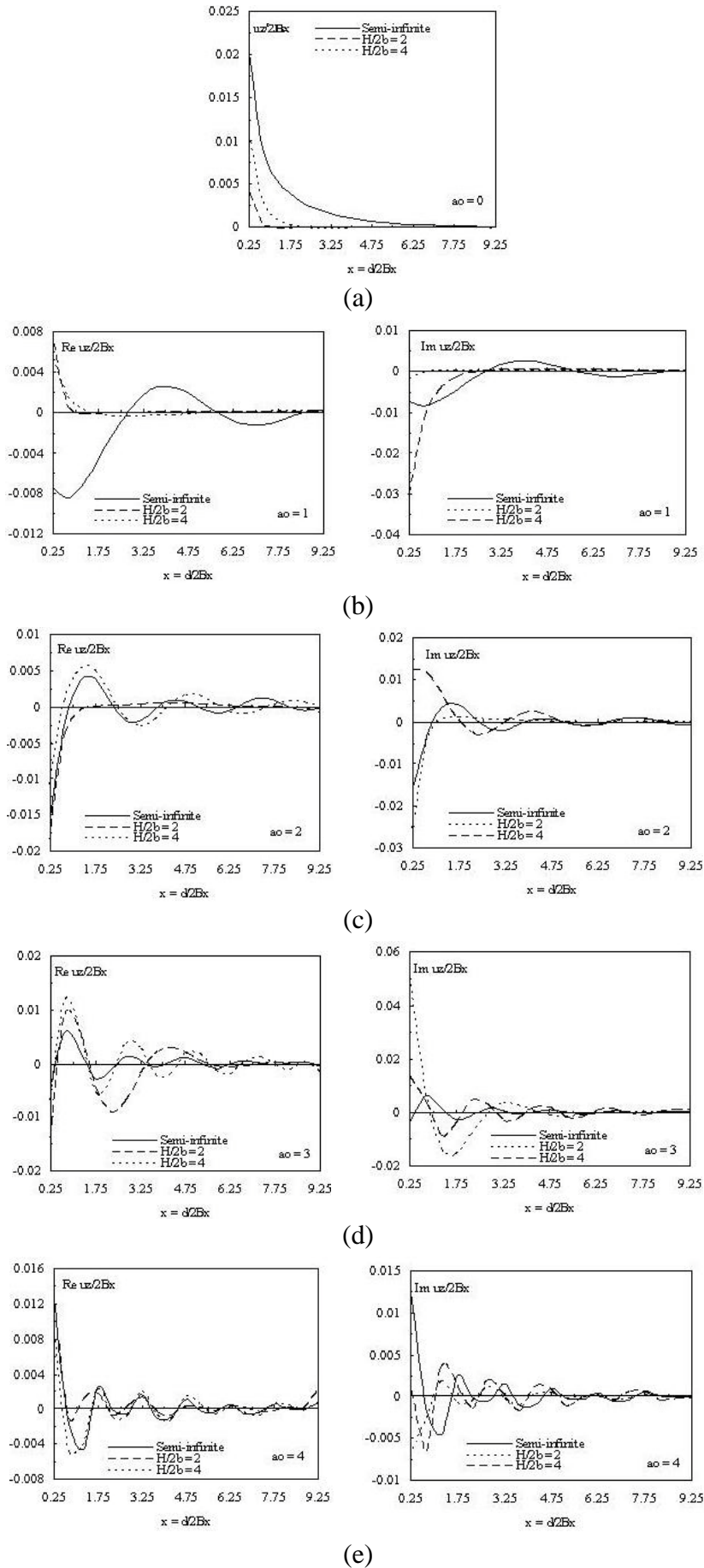

Fig. 10 Amplitude of vertical displacement along free surface for varying depths of the substratum and frequency a_0 equal to (a) 0, (b) 1, (c) 2, (d) 3, (e) 4

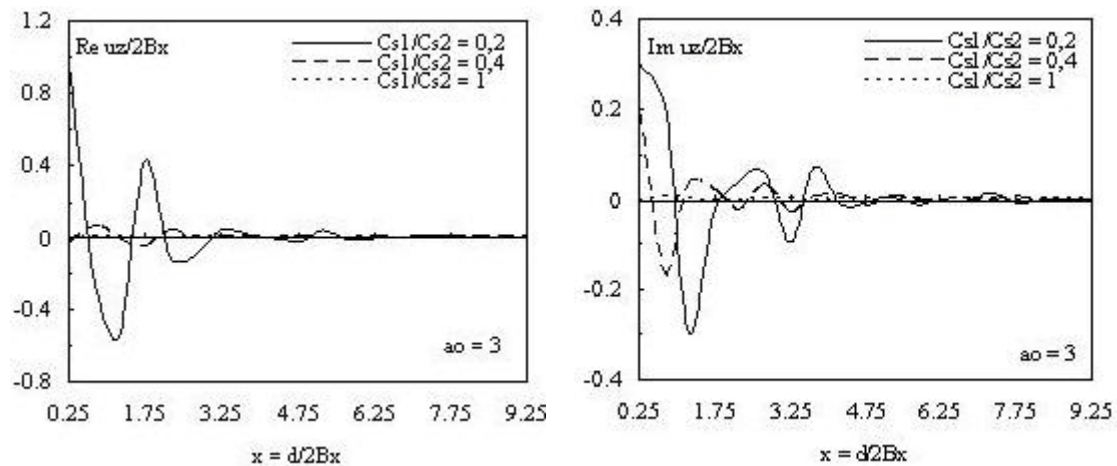

Fig. 11 Amplitude of vertical displacement along free surface for varying shear wave velocity ratio of the soil layer

ACKNOWLEDGEMENTS

The authors are grateful to the Ministry of Higher Education and Scientific Research for supporting this work under grant No. J2501/04/02/05. The calculation program developed during this work represents a continuity of the FONDVIB program worked out within the Soil Mechanics Laboratory of the Free Brussels University of Belgium by the coauthor, Professor A. Boumekik, in collaboration with Professors J. Nuyens and I.C. Constantopoulos.

REFERENCES

1. Ahmad, S. and Rupani, A.K. (1999). "Horizontal Impedance of Square Foundation in Layered Soil", *Soil Dynamics and Earthquake Engineering*, Vol. 18, No. 1, pp. 59–69.
2. Apsel, R.J. and Luco, J.E. (1987). "Impedance Functions for Foundations Embedded in a Layered Medium: An Integral Equation Approach", *Earthquake Engineering & Structural Dynamics*, Vol. 15, No. 2, pp. 213–231.
3. Beskos, D.E. (1987). "Boundary Element Methods in Dynamic Analysis", *Applied Mechanics Reviews*, Vol. 40, No. 1, pp. 1–23.
4. Beskos, D.E., Dasgupta, B. and Vardoulakis, I.G. (1986). "Vibration Isolation Using Open or Filled Trenches", *Computational Mechanics*, Vol. 1, No. 1, pp. 43–63.
5. Boumekik, A. (1985). "Fonctions Impédances d'une Fondation Vibrante en Surface ou Partiellement Encastrée dans un Sol Multicouche", Ph.D. Thesis, Université Libre de Bruxelles, Brussels, Belgium (in French).
6. Boumekik, A., Nuyens, J. and Constantopoulos, I.C. (1984). "Soil-Structure Interaction Effect on Noncircular Structure Embedded in Multilayered Soil", *Annales des Travaux Publics de Belgique*, Vol. 6, No. 3, pp. 563–592.
7. Chang-Liang, V. (1974). "Dynamic Response of Structures in Layered Soils", Ph.D. Thesis, Massachusetts Institute of Technology, Cambridge, U.S.A.
8. Cheng, Y.K. (1977). "Beams, Slabs, and Pavements" in "Numerical Methods in Geotechnical Engineering (edited by C.S. Desai and J.T. Christian)", McGraw-Hill, New York, U.S.A.
9. Dominguez, J. (1978). "Dynamic Stiffness of Rectangular Foundations", Report R78-20, Department of Civil Engineering, Massachusetts Institute of Technology, Cambridge, U.S.A.
10. Ewing, W.M., Jardetzky, W.S. and Press, F. (1957). "Elastic Waves in Layered Media", McGraw-Hill, New York, U.S.A.
11. Gupta, R.N. (1966). "Reflection of Elastic Waves from a Linear Transition Layer", *Bulletin of the Seismological Society of America*, Vol. 56, No. 2, pp. 511–526.

12. Haskell, N.A. (1953). "The Dispersion of Surface Waves on Multilayered Media", *Bulletin of the Seismological Society of America*, Vol. 43, No. 1, pp. 17–34.
13. Kausel, E. and Peek, R. (1982). "Dynamic Loads in the Interior of a Layered Stratum: An Explicit Solution", *Bulletin of the Seismological Society of America*, Vol. 72, No. 5, pp. 1459–1481.
14. Kausel, E. and Roesset, J.M. (1981). "Stiffness Matrices for Layered Soils", *Bulletin of the Seismological Society of America*, Vol. 71, No. 6, pp. 1743–1761.
15. Kausel, E., Roesset, J.M. and Waas, G. (1975). "Dynamic Analysis of Footings on Layered Media", *Journal of the Engineering Mechanics Division, Proceedings of ASCE*, Vol. 101, No. EM5, pp. 679–693.
16. Król, W. (1971). "Statique des Fondations en Béton Armé, Compte Tenue de la Rigidité de la Superstructure", *Dunod Éditeur, Paris, France* (in French).
17. Lamb, H. (1904). "On the Propagation of Tremors over the Surface of an Elastic Solid", *Philosophical Transactions of the Royal Society of London—Series A*, Vol. 203, No. 359–371, pp. 1–42.
18. Lysmer, J. and Kuhlemeyer, R.L. (1969). "Finite Dynamic Model for Infinite Media", *Journal of the Engineering Mechanics Division, Proceedings of ASCE*, Vol. 95, No. EM4, pp. 859–877.
19. Lysmer, J. and Waas, G. (1972). "Shear Waves in Plane Infinite Structures", *Journal of the Engineering Mechanics Division, Proceedings of ASCE*, Vol. 98, No. EM1, pp. 85–105.
20. Lysmer, J., Tabatabaie-Raissi, M., Tajirian, F., Vahdani, S. and Ostadan, F. (1981). "SASSI: A System for Analysis of Soil Structure Interaction", *Report UCB/GT-81/02, University of California, Berkeley, U.S.A.*
21. Mylonakis, G., Nikolaou, S. and Gazetas, G. (2006). "Footings under Seismic Loading: Analysis and Design Issues with Emphasis on Bridge Foundations", *Soil Dynamics and Earthquake Engineering*, Vol. 26, No. 9, pp. 824–853.
22. Reissner, E. (1936). "Stationäre, Axialsymmetrische, durch eine Schüttelnde Masse Erregte Schwingungen eines Homogenen Elastischen Halbraumes", *Ingenieur-Archiv*, Vol. 7, No. 6, pp. 381–396 (in German).
23. Richart Jr., F.E., Hall Jr., J.R. and Woods, R.D. (1970). "Vibrations of Soils and Foundations", *Prentice-Hall, Englewood Cliffs, U.S.A.*
24. Takahashi, D. (1985). "Wave Propagation in Ground-Structure Systems with Line Contact", *Journal of Sound and Vibration*, Vol. 101, No. 4, pp. 523–537.
25. Takahashi, D. (1986). "Wave Propagation in Ground-Structure Systems, Part I: Analysis of the Model with Surface Contact", *Journal of Sound and Vibration*, Vol. 105, No. 1, pp. 27–36.
26. Thomson, W.T. (1950). "Transmission of Elastic Waves through a Stratified Soil Medium", *Journal of Applied Physics*, Vol. 21, No. 2, pp. 89–93.
27. Waas, G. (1972). "Linear Two-Dimensional Analysis of Soil Dynamics Problems in Semi-infinite Layered Media", *Ph.D. Thesis, University of California, Berkeley, U.S.A.*
28. Wolf, J.P. (2002). "Response of Unbounded Soil in Scaled Boundary Finite-Element Method", *Earthquake Engineering & Structural Dynamics*, Vol. 31, No. 1, pp. 15–32.
29. Wong, H.L. and Luco, J.E. (1978). "Tables of Impedance Functions and Input Motions for Rectangular Foundations", *Report CE 78-15, University of Southern California, Los Angeles, U.S.A.*
30. Wong, H.L. and Luco, J.E. (1985). "Tables of Impedance Functions for Square Foundations on Layered Media", *Soil Dynamics and Earthquake Engineering*, Vol. 4, No. 2, pp. 64–81.