

## **SEISMIC ANALYSIS AND DESIGN OF STRUCTURES WITH VISCOELASTIC DAMPERS**

K.C. Chang\*, Y.Y. Lin\*\* and M.L. Lai\*\*\*

\*Professor, Department of Civil Engineering, National Taiwan University, Taipei, Taiwan

\*\*Graduate Student, Department of Civil Engineering, National Taiwan University, Taipei, Taiwan

\*\*\*R & D Specialist, 3M Company, St. Paul, USA

### **ABSTRACT**

This paper is concerned with seismic analysis and design of structures with added viscoelastic (VE) dampers. Based on the experimental and analytical results obtained earlier, a seismic design procedure for structures with added VE dampers is proposed with an example illustrating the proposed design procedure. Comparisons on the seismic performance between the viscoelastically damped structure and a conventionally designed special moment resisting frame are carried out. It is shown that the proposed design procedure provides an alternative safe and economic solution for earthquake resistant structures under current seismic design regulations. In addition, it is shown that with a sufficiently large design damping ratio, such as 15 % in this study, structures with added VE dampers may remain elastic or experience only minor yielding under most current design earthquakes.

**KEYWORDS:** Viscoelastic Damper, Damping Ratio, Seismic Design

### **INTRODUCTION**

Earthquake resistant design and retrofit of structures using energy absorption devices have received considerable attention in recent years (ATC 1993, EERI 1993). Among the available devices, viscoelastic (VE) dampers have shown to be capable of providing structures with considerable added damping to dissipate the seismic input energy (Aiken and Kelley 1990, Zhang and Soong 1992, Bergman and Hanson 1993).

Recently, comprehensive experimental and analytical studies on the application of VE dampers to structures have been carried out. Results from those studies show that the VE dampers are very effective in reducing vibrations of structures at all environmental temperatures under mild and strong earthquake ground motions. (Chang et al. 1992, 1993, 1995). The ductility demand of structures with added VE dampers can therefore be significantly reduced (Shen et al. 1995, Chang 1996). Studies also showed that damping ratios of the viscoelastically damped structures can be accurately estimated by the modal strain energy method and seismic response of the structures can be well predicted by conventional elastic and inelastic structural dynamic theories (Chang et al. 1995). In addition, experimental studies on a full-scaled steel frame show that damping in the structure can be significantly increased by incorporating VE dampers and that the damper design procedures experienced from the small scaled models can be used for full-scale structures (Lai et al. 1995).

This paper describes a design procedure for seismic retrofit and for design of new structures with added VE dampers based on the above studies. A design example of viscoelastically damped structure following the recommendations of NEHRP (1994) is made to illustrate the proposed design procedure. Analyses are also carried out to compare the safe and economic features between the viscoelastically damped structure and a conventionally designed special moment resisting frame. It is found that the proposed design procedure for viscoelastically damped structures described in this paper provide a safe and economic alternative for the design resistant structures under current seismic design regulations. Results from this study also suggest that with a design damping ratio of 15 %, it is possible to design a viscoelastically damped structure which performs elastically or experiences only minor yielding under strong earthquake ground motions.

## VISCOELASTIC DAMPER PROPERTIES AND BEHAVIOUR

The properties of the viscoelastic damper (Figure 1) are usually described in terms of its storage modulus  $G'$ , loss modulus  $G''$ , and loss factor  $\eta_v$  (Mahmoodi 1969), etc. In general, they depend on the loading frequency and the environmental temperature and can be described through various viscoelastic modeling methods (Kasai et al. 1993, Shen and Soong 1995, Chang et al. 1998).

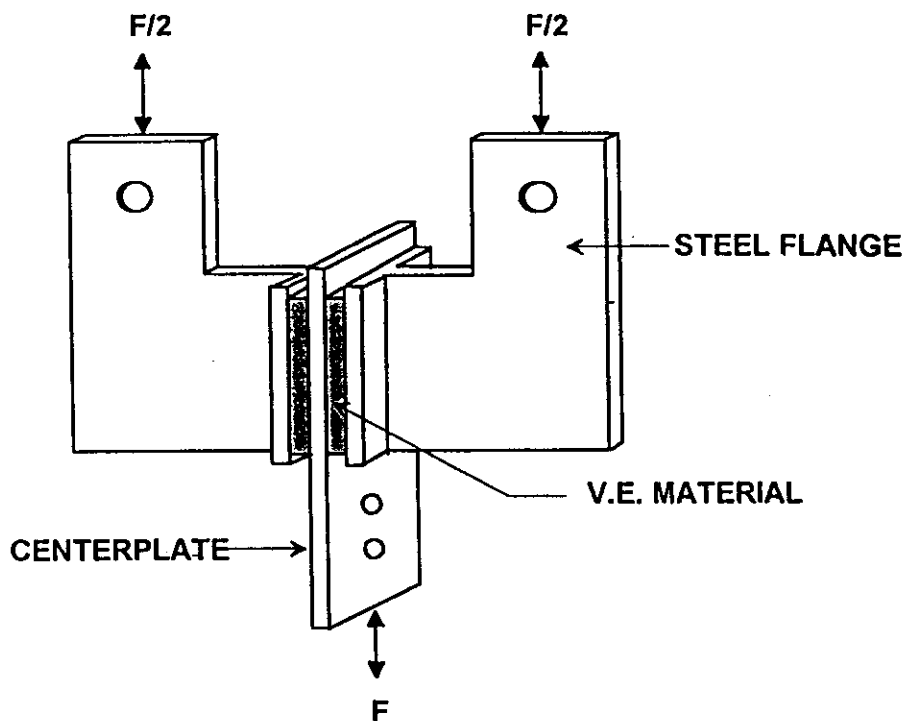

Fig. 1 Layout of viscoelastic dampers

For practical applications, it has been demonstrated that the damper properties can be obtained from regression analysis on the test data to include the effect of frequency and ambient temperature (Chang et al. 1996). For example, the damper property of 3M ISD110 viscoelastic material may be expressed as

$$G' = e^{10.17443T - 3.10205} F^{0.475466} \quad (1)$$

$$\eta_v \approx 1.2$$

where  $G'$  = damper storage modulus (MPa) at 20% strain,  $e$  = natural logarithm,  $T$  = temperature ( $^{\circ}\text{C}$ ),  $F$  = frequency (Hz). Figure 2 show a typical predicted curve using Equation (1) and the test result of  $G'$  at various ambient temperatures and frequencies. Equation (1) will be used in the design example in this paper.

In carrying out seismic analyses of viscoelastically damped structures, it may be desirable to know how the VE dampers behave and how much damper temperature may rise during an earthquake. In general, they can be obtained by implementing appropriate VE damper models in the analyses (Kasai et al. 1993, Chang et al. 1998). For practical applications, they may also be obtained as follows.

It is known that the force and deformation of a VE damper under sinusoidal excitation is out-of-phase by a phase angle  $\delta$ . When carrying out dynamic analyses using commonly used linear analysis tools, the resulting force-deformation relationship of the VE damper is linear without any phase lag and its peak force value obtained is less than the maximum damper force. For design purposes, the damper force-deformation can be estimated from the time history analysis result of the linear truss element by lagging the deformation of the VE brace behind the corresponding damper force by a time equal to  $\delta/2\pi\omega$ , and increase the damper force by a factor equal to  $\sqrt{1+\eta_v^2}$ , where  $\delta$  is the phase angle of the

VE damper and  $\eta$ , is the damper loss factor. Figure 3a shows a typical damper force deformation curves obtained using this approach. Comparing with the experimental result (Figure 3b), it is clear that the damper force-deformation curves may also be obtained without resorting to complicated viscoelastic modeling.

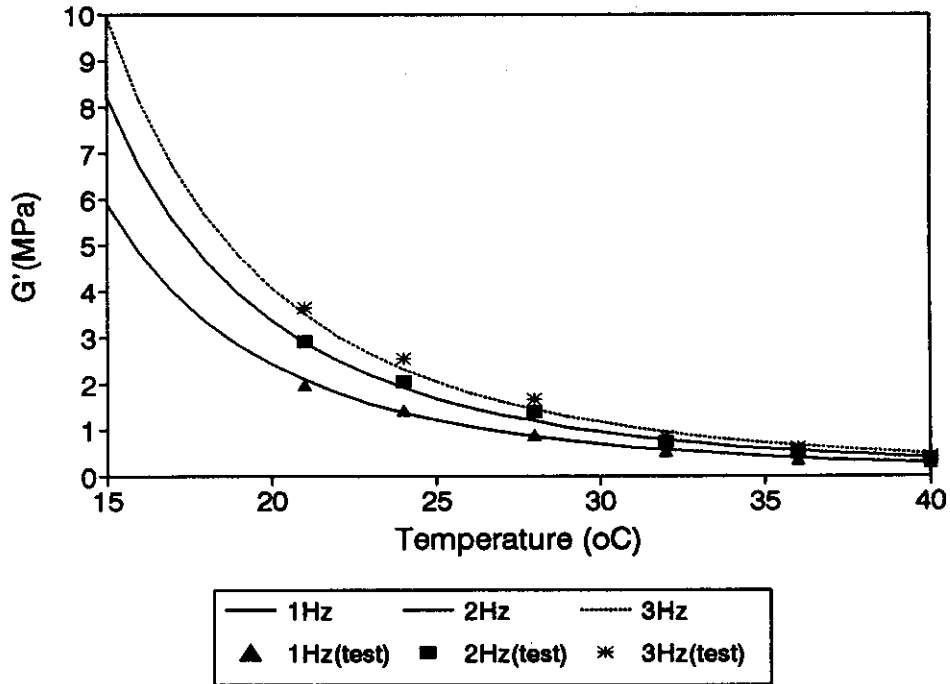

Fig. 2 Temperature effect on  $G'$

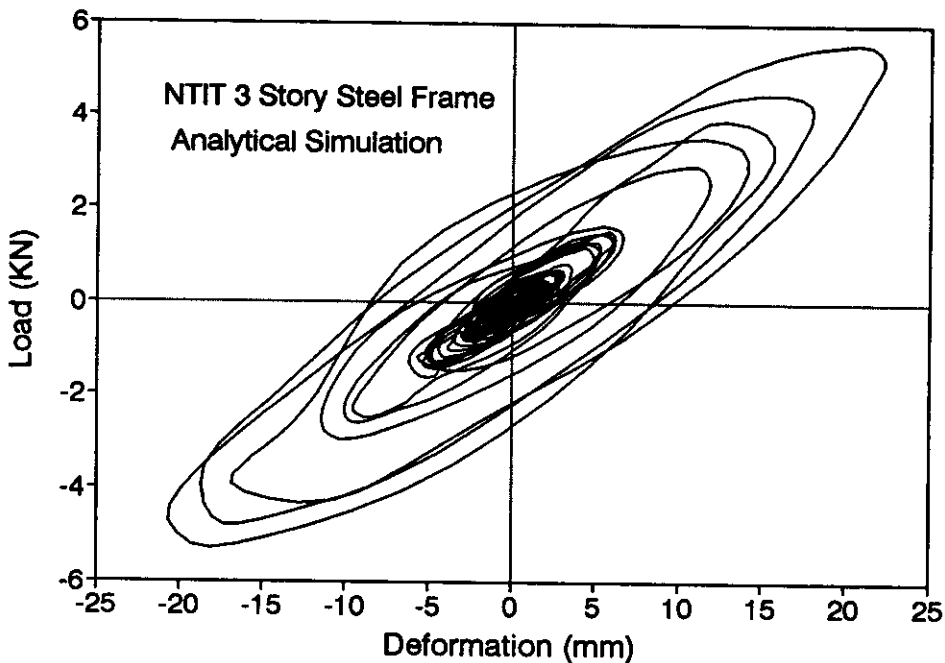

Fig. 3a Damper load-deformation curve, 0.5g El Centro, damper L, analytical simulation

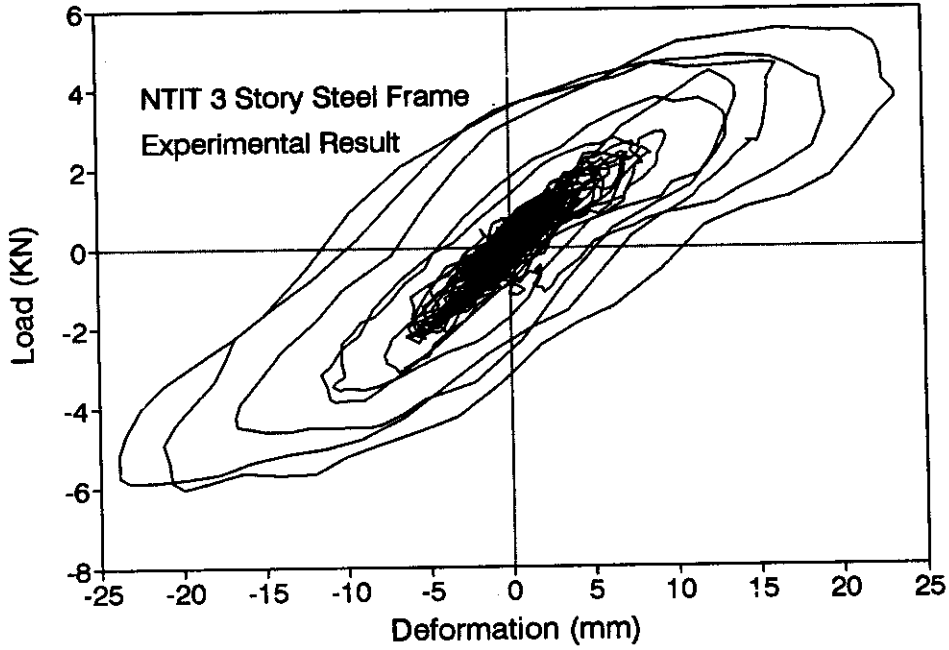

Fig. 3b Damper load-deformation curve, 0.5g El Centro, damper L, experimental result

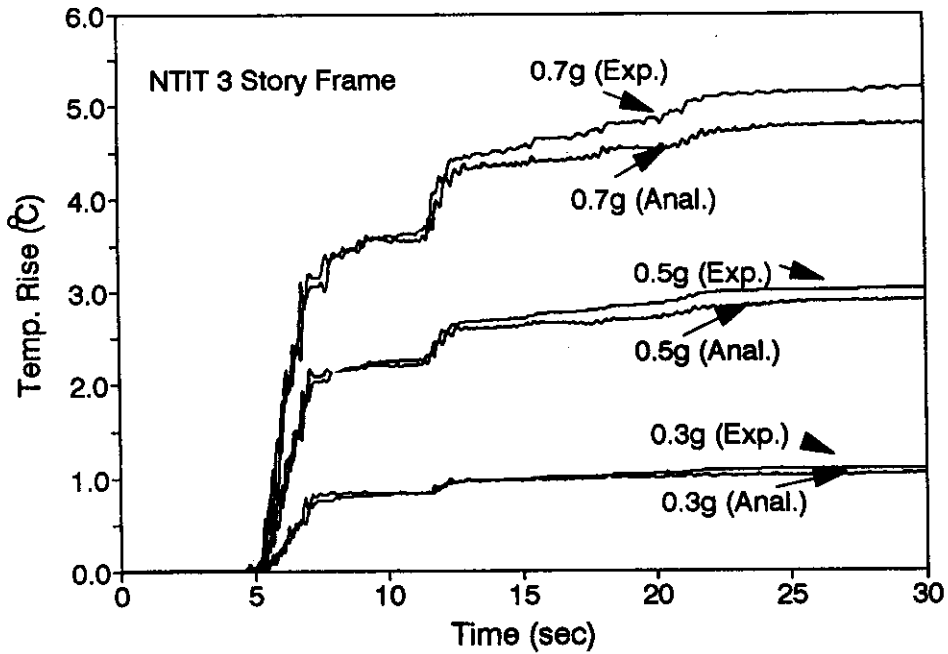

Fig. 4 Temperature rise of VE Damper, El Centro earthquake

Once the damper-force deformation curves are obtained, the temperature rise within damper material during an earthquake can be estimated by (Kasai et al. 1993)

$$T(t) = T_0 + \frac{1}{s\rho} \int_0^t \tau \, d\gamma \tag{2}$$

where  $T(t)$  = temperature in °C within damper material at time  $t$ ;  $T_0$  = initial ambient temperature of the damper;  $s$  and  $\rho$  = specific heat and mass density of the damper material, respectively. Figure 4 show the predicted and measured temperature rise of the VE dampers at the first story of a 2/5 scale 3 story model under El Centro earthquakes scaled to various peak ground accelerations. It should be noted

that, for simplicity, Figures 3a and 4 did not consider the softening effect of VE dampers due to temperature rise within damper materials during the earthquake. They can be easily included in the analysis if more accurate result is required.

**SEISMIC STRUCTURAL RESPONSE AND ANALYSIS**

**1. Equivalent Strain Energy Method of Analysis**

The modal strain energy method has been studied extensively (Johnson and Kienholz 1982, Zambrano et al. 1996) and successfully applied to predict the equivalent damping ratios of the structures with added VE dampers (Chang et al. 1992, 1995). In this approach, if inherent damping of the structure without added VE dampers is small, the damping ratios of the viscoelastically damped structure can be expressed as

$$\xi_i = \frac{\eta_{v-b}}{2} \left( 1 - \frac{\phi_i^T K_0 \phi_i}{\phi_i^T K_s \phi_i} \right) \tag{3}$$

where

- $\xi_i$  = equivalent damping ratio for the  $i^{\text{th}}$  vibration mode;
- $K_0$  = stiffness matrix of the structure without added VE dampers;
- $K_s$  = stiffness matrix of the viscoelastically damped structure;
- $\phi_i$  = the  $i^{\text{th}}$  vibration mode shape of the viscoelastically damped structure;
- $\eta_{v-b}$  = the effective loss factor of the viscoelastic dampers assembly determined as

$$\eta_{v-b} = \frac{\frac{k_b}{k_v}}{\eta_v^2 + \frac{k_b}{k_v} + 1} \eta_v \tag{4}$$

- $\eta_v$  = loss factor of the VE damper;
- $k_b$  =stiffness of the damper brace;
- $k_v$  = stiffness of the VE damper.

If the change of vibration mode shapes due to the addition of VE dampers can be neglected, Equation (3) can be reduced to

$$\xi_i = \frac{\eta_{v-b}}{2} \left( 1 - \frac{\omega_i^2}{\omega_{si}^2} \right) \tag{5}$$

where  $\omega_i$  and  $\omega_{si}$  are the  $i^{\text{th}}$  natural frequencies of the structure without and with added dampers, respectively.

Equations (3) and (5) have been incorporated into the general purpose programs ETABS (Wilson et al. 1979) and Drain2D+ (Tsai and Li 1994) in this study and were verified by extensive experimental data described earlier. The measured and predicted modal damping ratios of the model structures are summarized in Figure 5 (Chang et al. 1995).

**2. Time History Analysis**

Once damping ratios of the viscoelastically damped structure are evaluated, seismic response analyses can be carried out using available structural dynamic analysis programs. Figure 6 shows a typical time history response prediction and test result of a five story model under 0.6g Hachinohe earthquake (Chang et al. 1995). In this study, the VE damper assemblies are modeled as truss elements

in the modified computer program ETABS with the inclusion of modal strain energy method. Similar studies have been carried out extensively and the results conclude that the elastic time-history response of viscoelastically damped structures can be well predicted if damping ratios of the structure can first be accurately predicted.

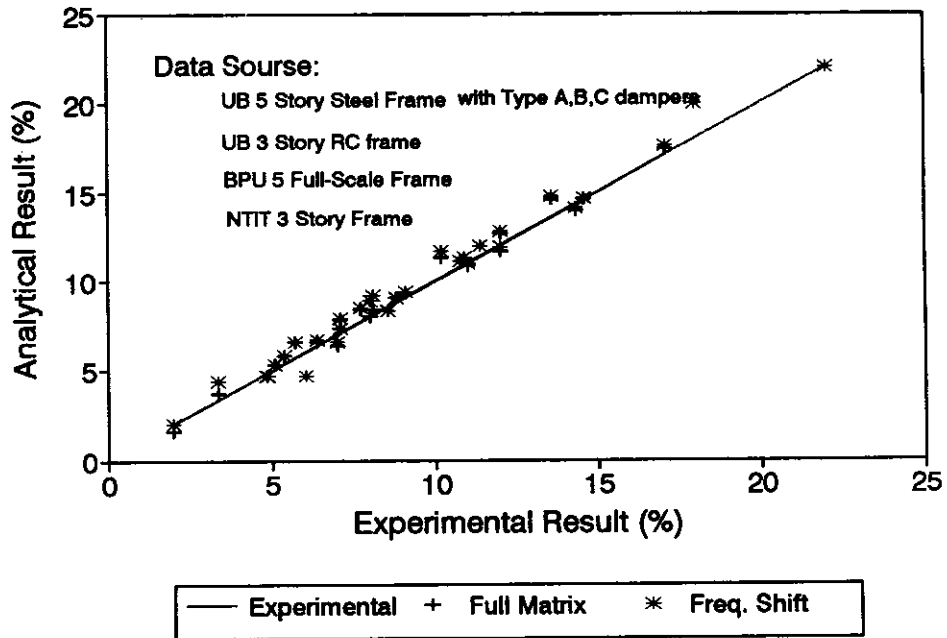

Fig. 5 Prediction of damping ratio, modal strain energy method

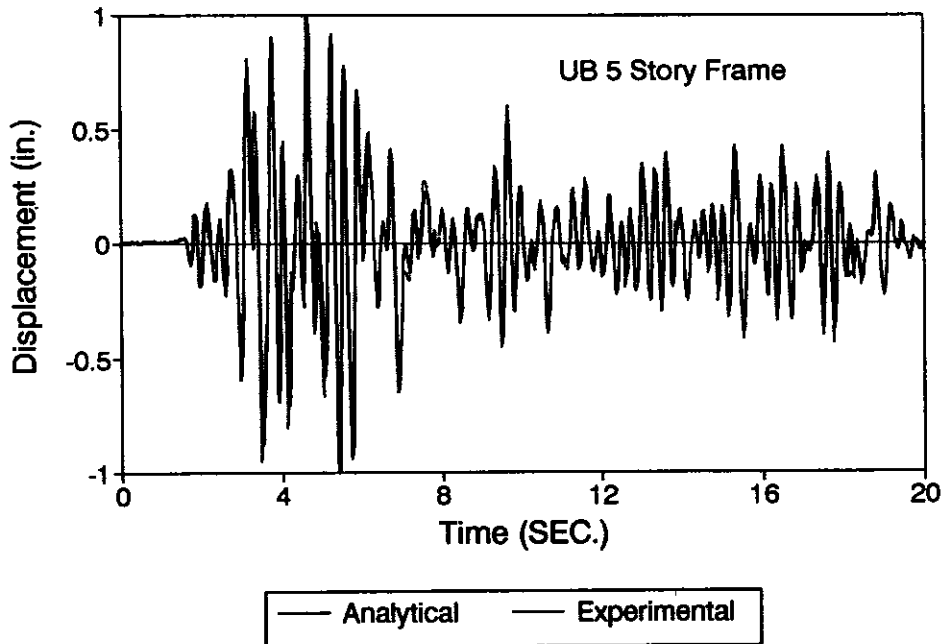

Fig. 6 Roof lateral displacement, 0.6g Hachinohe earthquake

Figure 7 shows an experimentally obtained and numerically simulated time-history responses of a 3 story steel frame with added VE dampers under 0.8g El Centro earthquake (Chang et al. 1996). The structural members and VE damper assemblies are modeled as bi-linear beam and column elements and truss elements, respectively, in Drain2D+. It can be seen that, in general, the analytical result predicts

the overall structural response well even though the structural members had experienced inelastic deformation during previous tests (Chang et al. 1996).

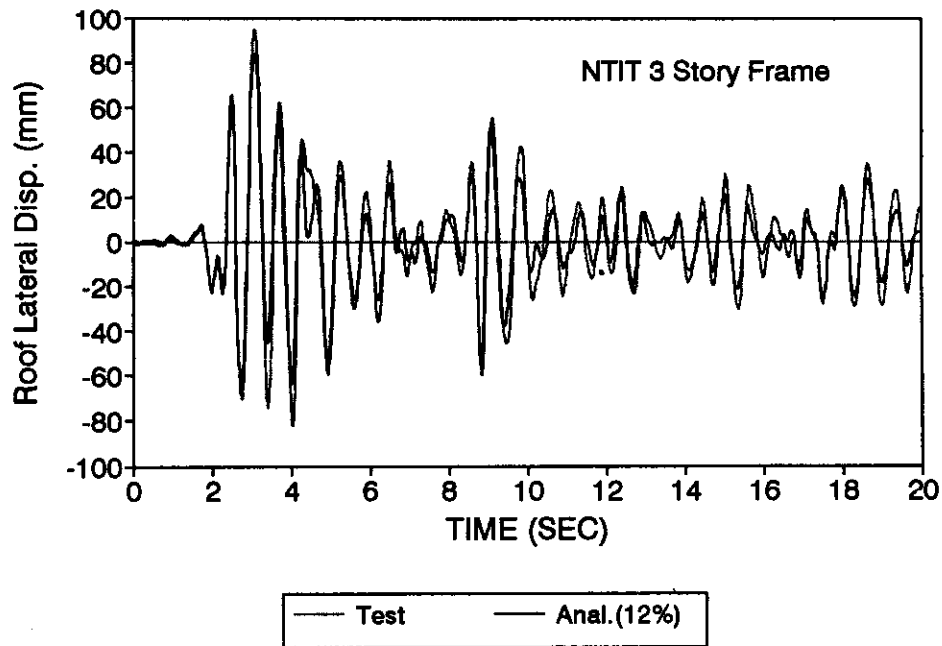

Fig. 7 Seismic response simulation, 0.8g El Centro, damper L

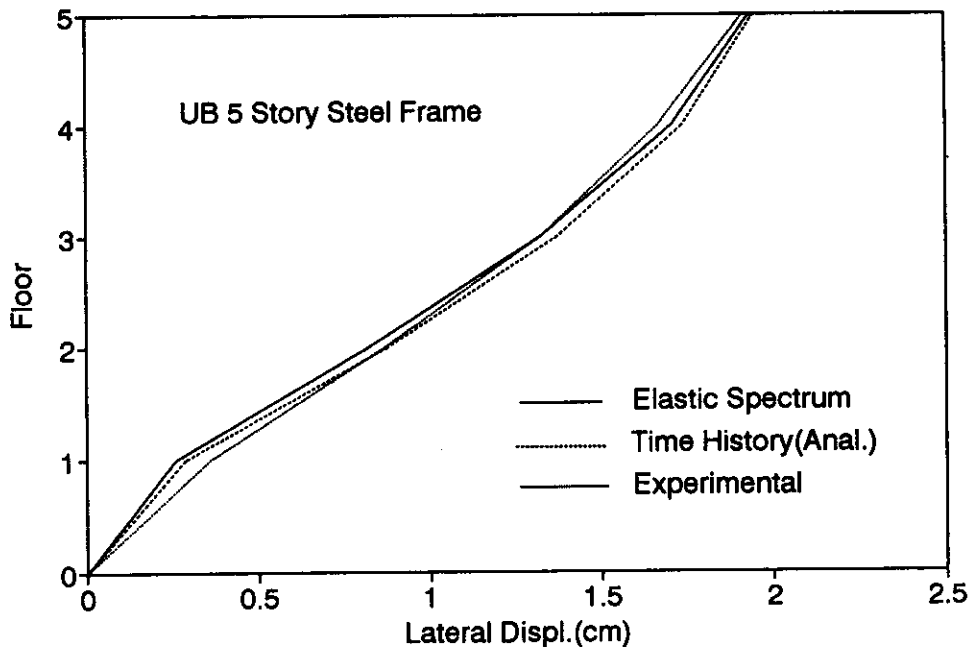

Fig. 8a Response spectrum analysis, 0.6g El Centro, 15% damping, lateral displacement

### 3. Response Spectrum Analysis

For structures with VE dampers, the seismic response envelopes of the structure can be also carried by response spectrum analysis using the response spectra of the input ground motions with damping ratios calculated from Equation (3). Figures 8a and 8b show typical results of the floor lateral displacement and story shear envelopes of a 5-story steel frame with added VE dampers ( $\xi = 15\%$ ) under 0.6g El Centro earthquake using the CQC method (Kiureghian 1981). The structure remained

elastic during the earthquake. Also included in these figures are the envelopes of experimental and analytical time history analysis results. It can be seen that the response spectrum analysis gives reliable predictions on the lateral displacement and story shear envelopes of the viscoelastically damped structure.

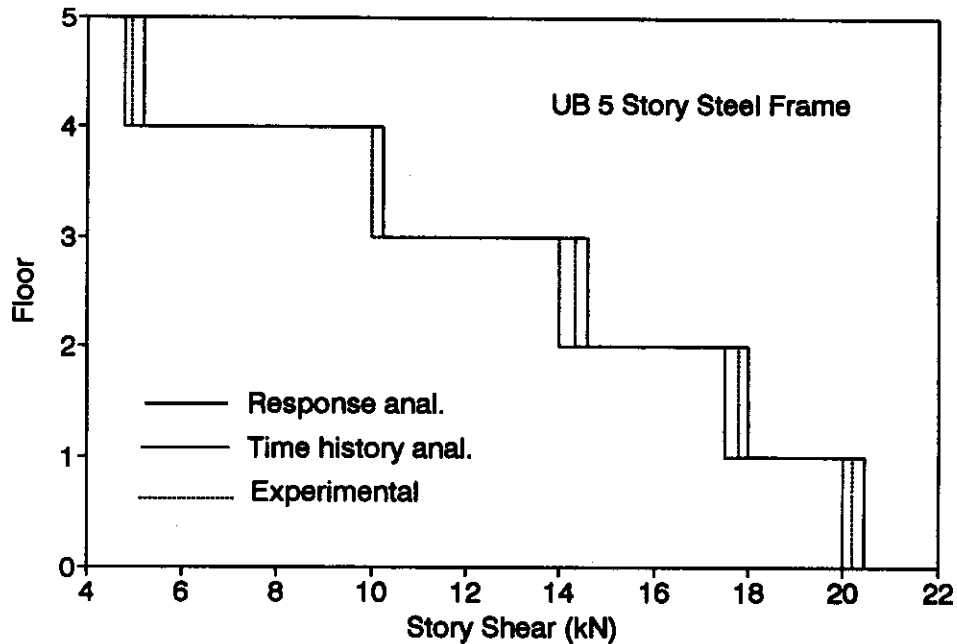

Fig. 8b Response spectrum analysis, 0.6g El Centro, 15% damping, story shear

## DESIGN PROCEDURE

### 1. Principle of Design

Viscoelastic dampers can be applied either to retrofit existing structures or to design new structures. To design a new structure with added VE dampers, member sizes of the primary frame (the moment resisting frame without the damper braces) may be determined according to the design damping ratio as follows.

If the change of mode shapes due to the added dampers is neglected, the modal strain energy equation can be approximated as

$$\xi = \frac{\eta_{v-b} K_d}{2 K_s} = \frac{\eta_{v-b}}{2} \left( \frac{K_d}{K_0 + K_d} \right) \quad (6)$$

where  $\xi$  = design damping ratio,  $\eta_{v-b}$  = loss factor of the VE damper assembly as given in Equation (4),  $K_d$  = the lateral stiffness contribution of the VE damper assembly,  $K_0$  = lateral stiffness contribution of the primary frame, and  $K_s$  = lateral stiffness of the viscoelastically frame.

Assuming that the base shear is proportional to the structure's lateral stiffness, we have

$$V = V_d + V_0 = 2 \frac{\xi}{\eta_{v-b} - 2\xi} V_0 + V_0 \quad (7)$$

where  $V$  = the total design base shear specified by the building code,  $V_d$  = the base shear shared by the VE damper assembly, and  $V_0$  = design base shear for sizing the primary frame.

From Equation (7), the primary frame may be designed by the base shear as



$$V_0 = B \frac{\eta_{v-b} - 2\xi}{\eta_{v-b}} V \tag{8}$$

where  $B$  is the reduction factor for damping ratio greater than 5 % (NEHRP 1994). Figure 9 shows the relationship between design damping ratio and  $V_0/V$  which is the design base shear ratio shared by the primary frame.

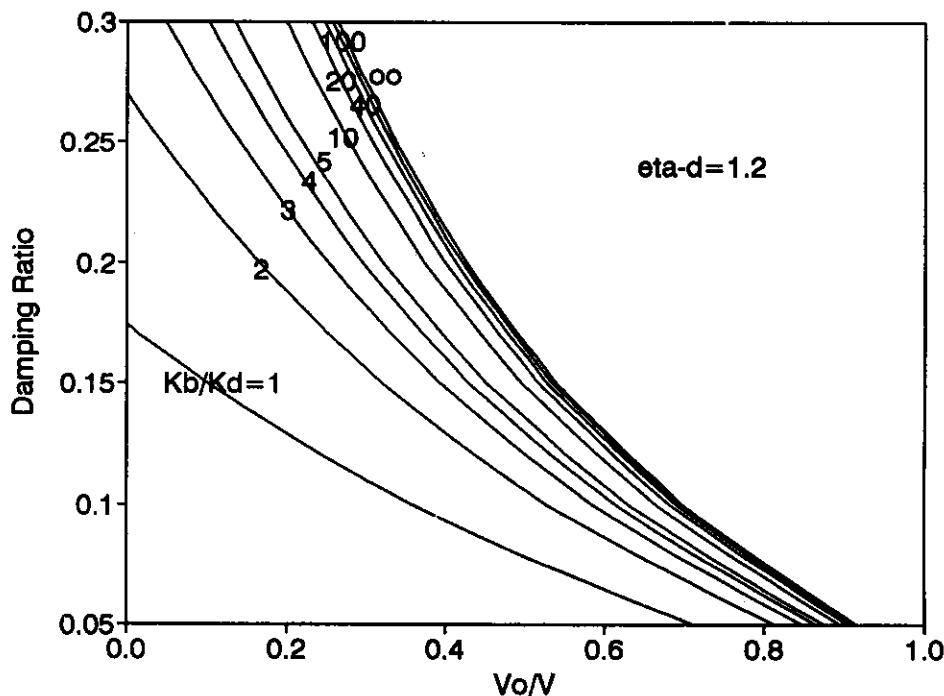

Fig. 9 Design base shear of primary frame

## 2. Design of the Viscoelastic Dampers

Once the primary frame is designed, the design of VE dampers for retrofitting existing frames and for designing new structures are similar. A complete design flow chart is given in Figure 10 and is illustrated as follows.

1. Determine desired damping ratio ( $\xi$ ).
2. Assume a stiffness ratio of the damper braces to the VE dampers ( $k_b / k'_v$ ), then the effective loss factor of the VE dampers assembly ( $\eta_{v-b}$ ) can be calculated from Equation (4).
3. Design the primary frame by Equation (8) or Figure 9 and select available damper locations.
4. Based on modal strain energy method (Equation (3) or (5)), the stiffness of the VE damper assembly ( $k_{v-b}$ ) can be determined.
5. From the combined relationship of the damper braces and the VE dampers, the storage stiffness of each VE damper ( $k'_v$ ) may be determined as

$$k'_v = \frac{\left[ (1 + \eta_v^2) + \frac{k_b}{k'_v} \right] [1 + \eta_{v-b}^2]}{\frac{k_b}{k'_v} (1 + \eta_v^2)} k_{v-b} \tag{9}$$

Consequently, the dampers can be designed.

6. According to the assumed stiffness ratio of the damper braces and the calculated VE damper stiffness of Equation (9), the stiffness of the damper brace ( $k_b$ ) can be calculated. Hence, the damper brace can be sized.
7. Estimate the damping ratio, and then carryout modal analysis or time-history analysis of the viscoelastically damped structure. If the design requirements are satisfied, the design is completed, or steps 1-7 should by repeated.

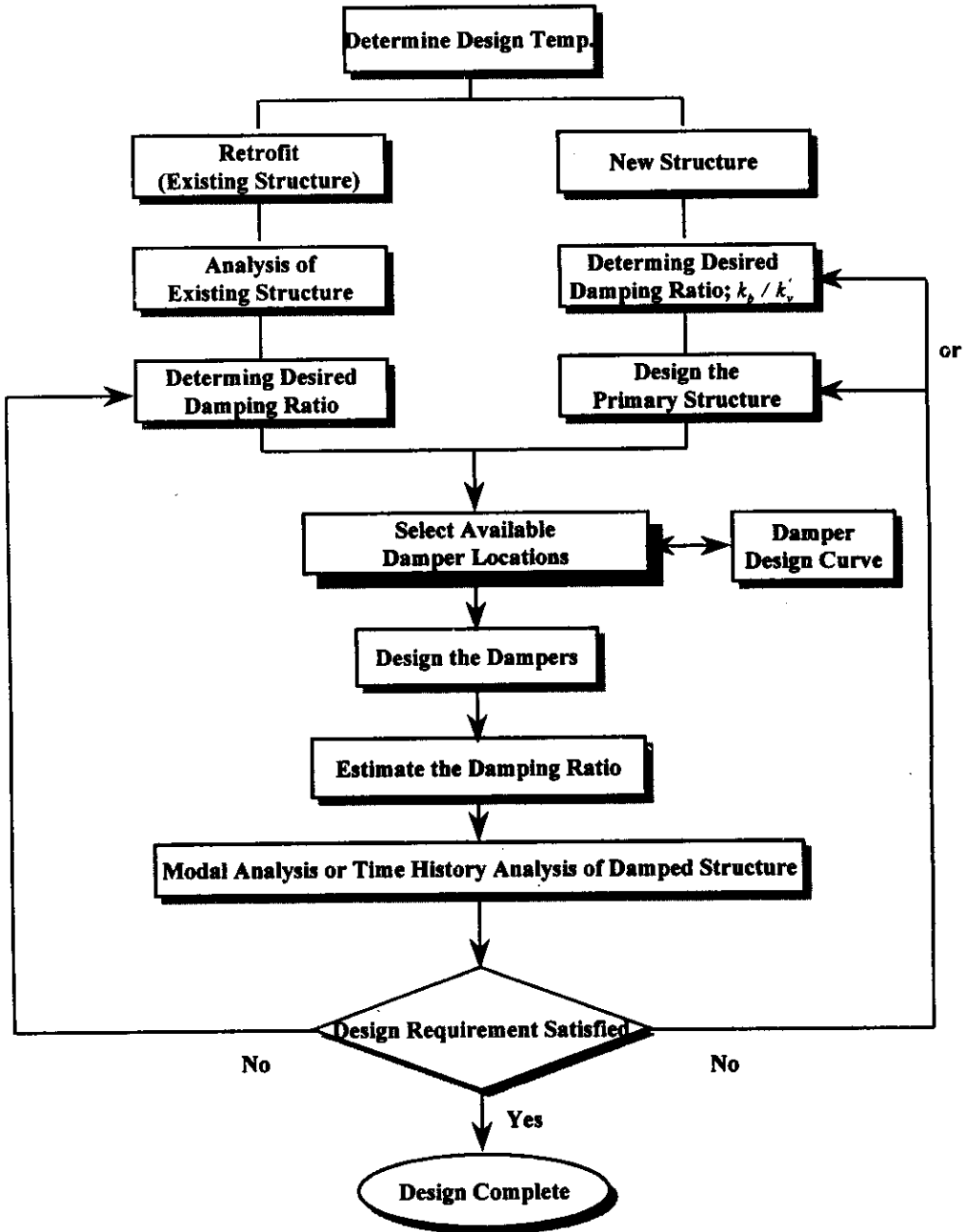

Fig. 10 Viscoelastic damper design procedure

**DESIGN EXAMPLES**

**1. Description of Design Parameters**

Seismic design and analysis of a five story steel structure with added VE dampers is presented to illustrate the proposed design procedure. In this example, structural members of the primary frame are sized based on Equation (8) following the requirements of NEHRP (1994). VE dampers are designed to provide 15 % damping ratio at 30°C (inherent damping of the primary frame is neglected). Moreover, the stiffness ratio of the VE dampers are assumed to be 40 at 30°C ( $k_b / k_v = 40$ ). Design parameters for the viscoelastically damped frame (VEDF) are summarized as follows.

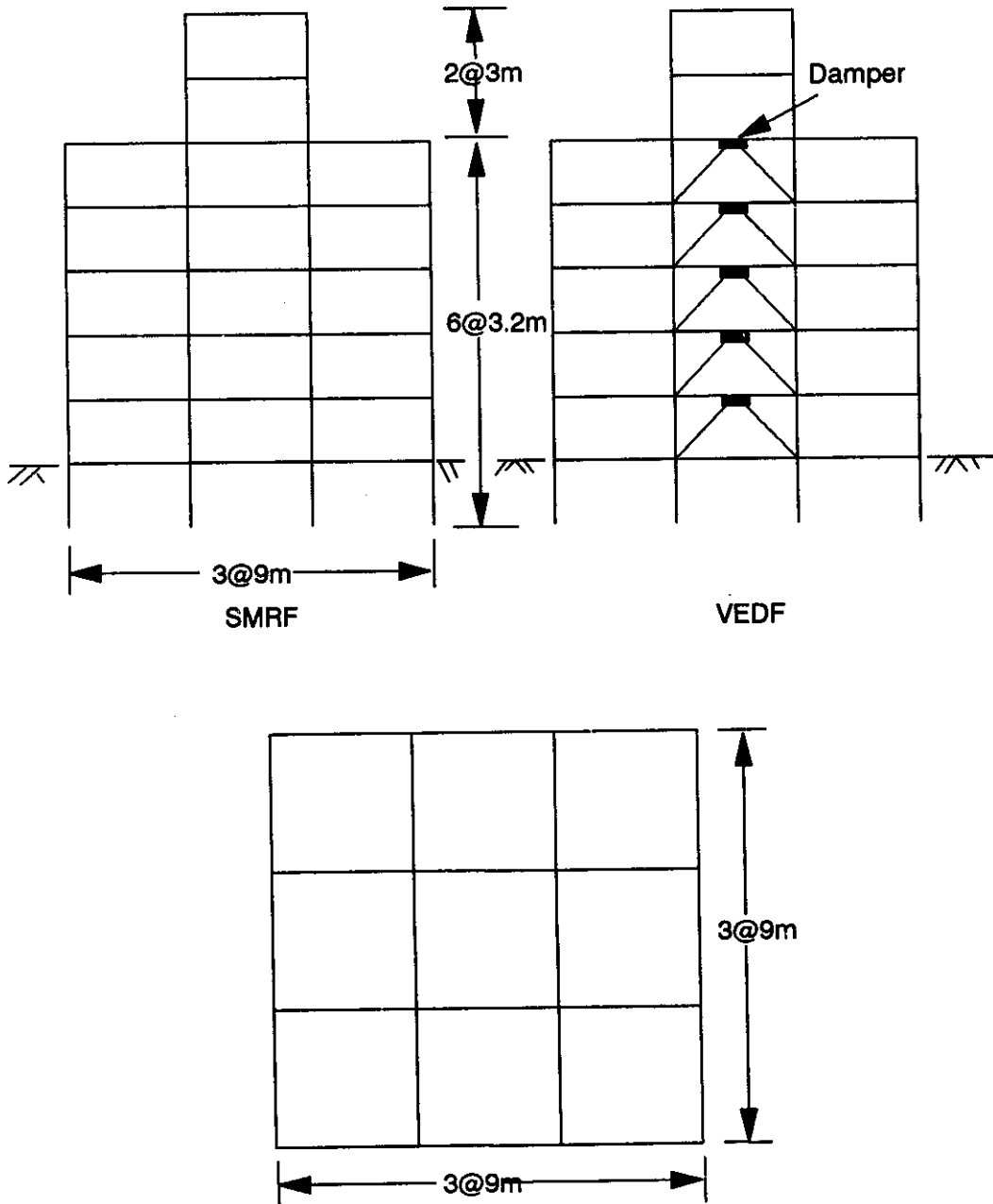

Fig. 11 5-story steel frame

1. Structural Layout: as shown in Figure 11.
2. Dead Load:  $7.06 \text{ kN/m}^2$ .  
Live Load:  $2.94 \text{ kN/m}^2$  (2-5 floor);  $6.44 \text{ kN/m}^2$  (roof).
3. Design Base Shear:  $V = C_s W = 0.1125W$  (NEHRP 1994), where  $C_s = 1.2 C_v / RT^{2/3} \leq 2.5 C_a / R$ ,  
 $C_a = 0.36$ ,  $C_v = 0.96$ ,  $R = 8$ .
4. Lateral Drift Limits:  $\Delta \leq (0.015) h_s$  under design earthquake,  $h_s$  = story height.
5. Design Temperature Range :  $15^\circ\text{C} \sim 30^\circ\text{C}$
6. VE Damper Properties:  $G'$  and  $\eta_v$  are given in Equation (1).
7. VE dampers are placed in the center core of the building.

For comparison purposes, a conventional special moment resisting steel frame (SMRF, 5 % inherent damping) satisfying the above design requirements is also designed to assess the safe and economic features of the viscoelastically damped structure. Artificial earthquake ground motions compatible with the normalized NEHRP (1994) design spectrum (Figure 12a,b) and a few recorded real earthquake ground motion records are used to compare the elastic and inelastic behavior of the two design cases using the previously mentioned design package.

Following the regular design procedure, structural members selected for the SMRF and the primary frame of the VEDF are listed in Table 1.

**Table 1: Structural Members for 5 Story Steel Frame**

Group Name	Floor Level	X-section SMRF	X-section VEDF
Interior Column	1-3	50x50x3x3	35x35x2.3x2.3
	4-5	50x50x1.5x1.5	35x35x1.5x1.5
Exterior Column	1-3	50x50x2.5x2.5	35x35x1.5x1.5
	4-5	50x50x1.2x1.2	35x35x1x1
Interior Beam	1-3	W21x93	W14x109
	4-5	W21x93	W14X109
Exterior Beam	1-3	W16x89	W14x61
	4-5	W14x82	W14x43
Brace	1-5		20x20x0.64x0.64
Weight	(ton)	926	695

(The unit of box column and tube brace are "cm")

## 2. Design of Viscoelastic Dampers

### 2.1 Determine the Damper Stiffness

With the locations of the VE dampers determined, the selection of the VE damper assembly stiffness,  $k_{v-b}$ , is in general a trial and error procedure. It can be determined by constructing VE damper assembly design curves using Equations (3) or (5). In this example, eight VE damper are used at the center core between the beams and K braces of each story (Figure 11). The VE damper assembly design curves are constructed by modeling the VE damper assembly as truss elements in ETABS modified with the inclusion of the modal strain energy method, as shown in Figures 13a and 13b. For the design damping ratio of 15 %, the VE damper assembly stiffness ( $k_{v-b}$ ) for the VEDF is determined to be  $235.44 \text{ kN/cm}$  ( $2400 \text{ tf/m}$ ) and the associated first natural frequencies of the viscoelastically damped structures will be  $0.866 \text{ Hz}$  ( $1.12 \text{ Hz}$  for the SMRF). According to Equation (9), the storage stiffness of the VE damper ( $k'_v$ ) is equal to  $233.28 \text{ kN/cm}$  ( $2378 \text{ tf/m}$ ). Then, using  $k_b / k'_v = 40$ , we have  $k_b = 40 k'_v = 9331.2 \text{ kN/cm}$  and the size of the brace members can be determined (Table 1). It can be seen that due to smaller design base shear, total structural weight of the viscoelastically damped frame is about 25% less than that of the conventional frame.

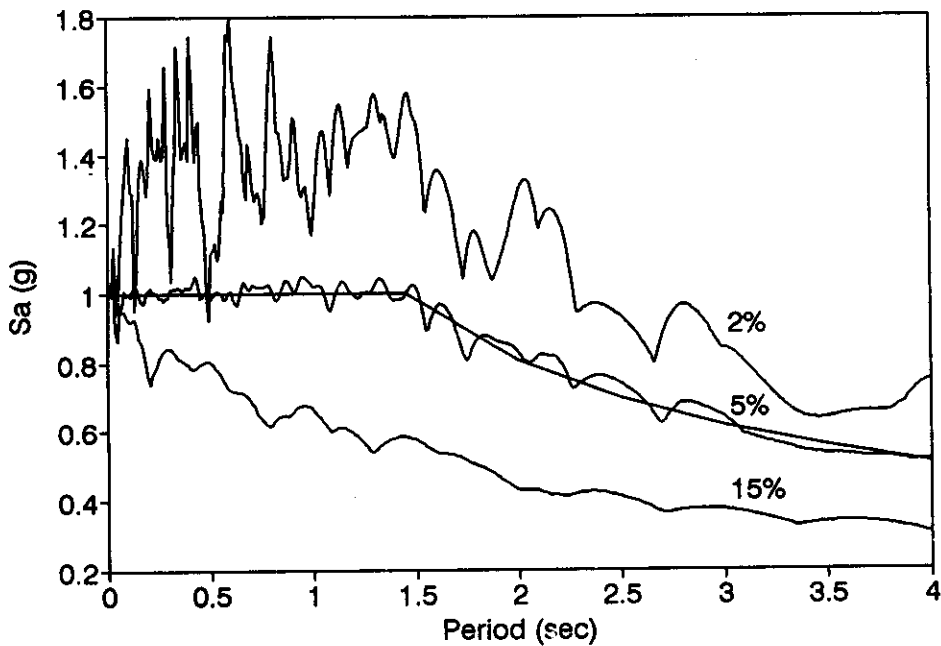

Fig. 12a Elastic response spectrum, NEHRP 1994

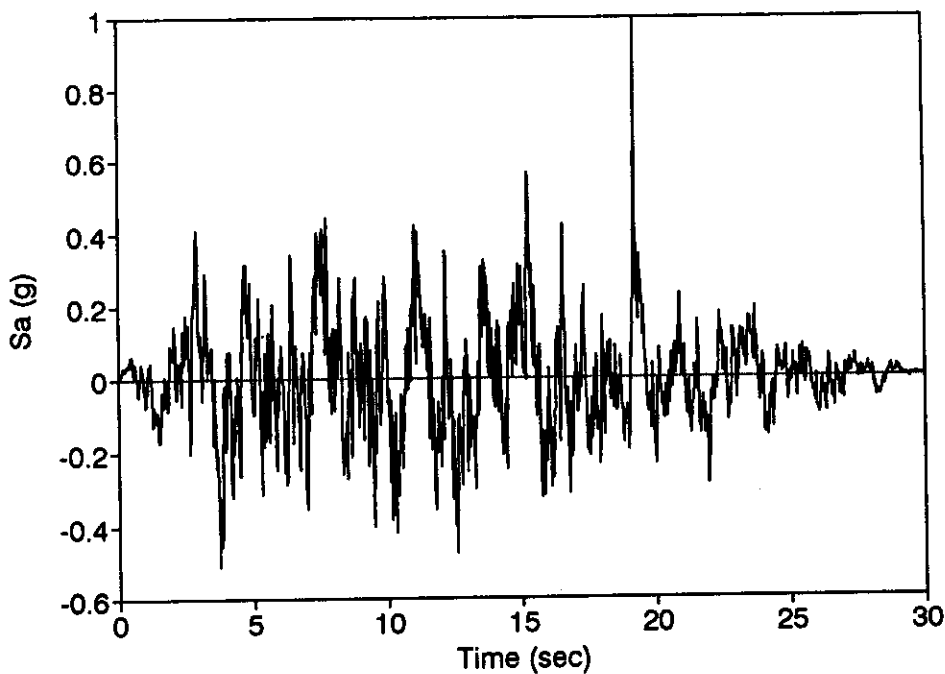

Fig. 12b Artificial earthquake, NEHRP 1994, design spectrum

### 2.2 Determine the Damper Thickness

The thickness of the VE material,  $h$ , can be determined based on the maximum allowable damper deformation. In this example, if the maximum damper deformation is governed by the maximum story drift ratio of 1.5 %, it will be limited to  $1.5 \% \times 320 \text{ cm} \times \cos \theta = 3.9 \text{ cm}$ , where 320 cm is the story height and  $\theta$  is the angle between the floor and the brace. If the maximum damper strain of 150 % is allowed for the design temperature of 30°C, the damper thickness is then determined to be 2.5 cm. It should be noted that for lower design temperature, smaller allowable damper strain may be adopted.

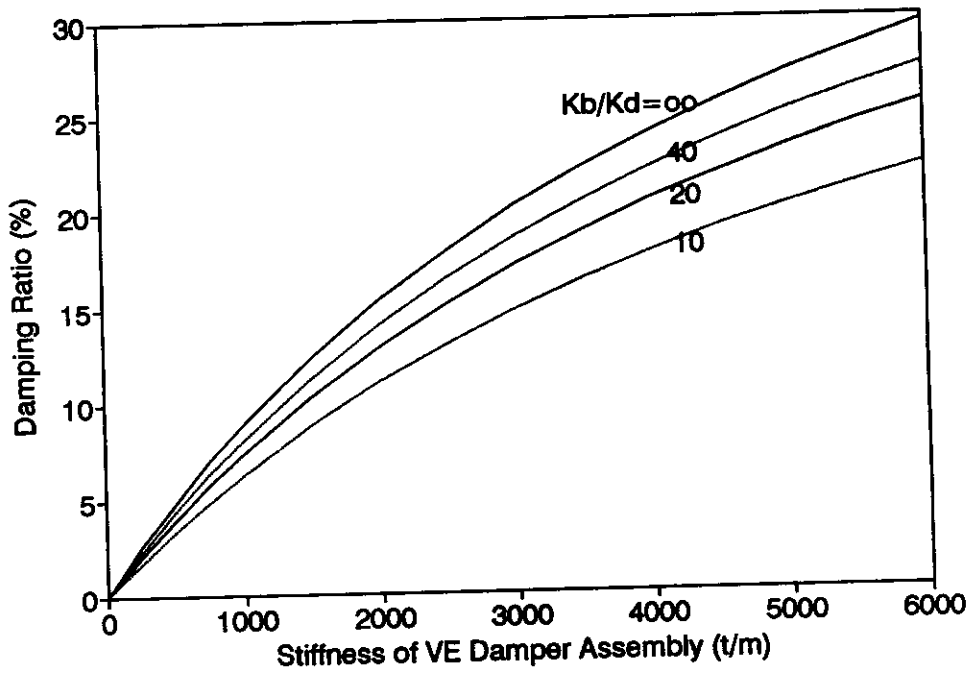

Fig. 13a Viscoelastic Damper Design Curve

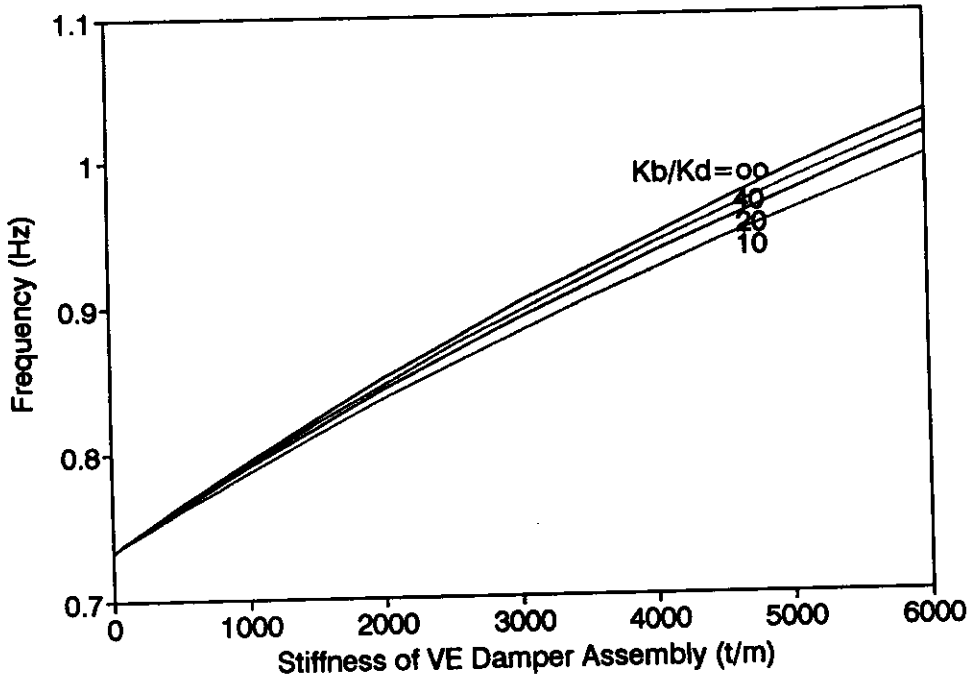

Fig. 13b Viscoelastic damper design curve

**2.3 Determine the Damper Area**

The area of the VE damper can be determined as

$$A = \frac{k_v h}{nG'} \tag{10}$$

where  $k_v = VE$  damper storage stiffness obtained from Figure 13a and Equation (9),  $h =$  damper thickness,  $n =$  number of VE layers for each damper,  $G' =$  storage modulus of the VE material which can be determined from the empirical equations such as Equation (1) with a specified design temperature and frequency.

In this example, if 3M ISD110 VE material is used, the storage modulus  $G'$  for design is 0.641 MPa at 30°C, 0.866 Hz and 20 % strain. If four VE layers are used for each damper, area of the VE dampers for this design case can be determined to be 2275 cm<sup>2</sup>. The final design of the VE dampers can then be determined as 4 × 30 cm × 76 cm × 2.5 cm as shown in Figure 14.

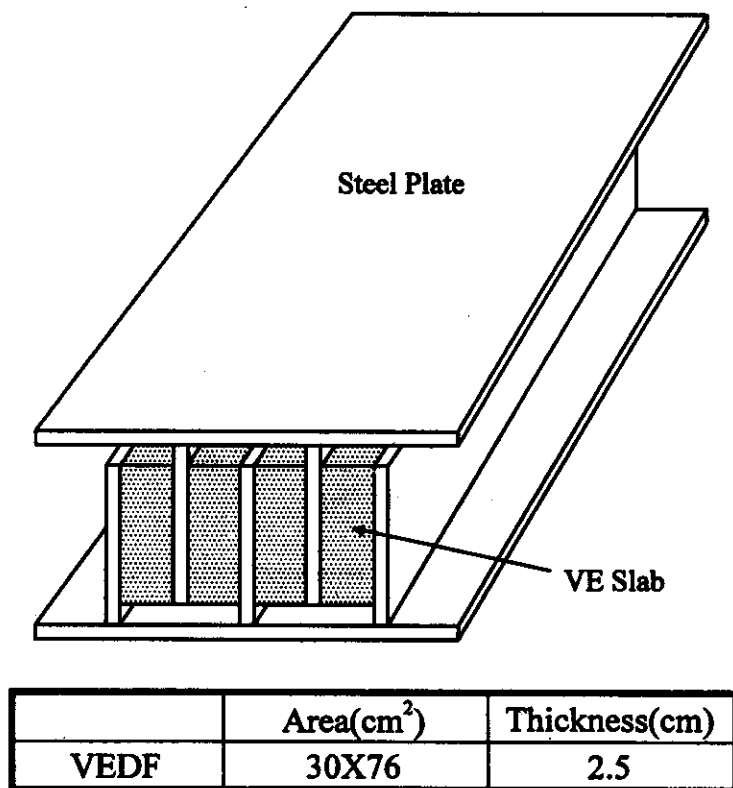

Fig. 14 Layout and dimension of viscoelastic dampers

### 2.4 Estimate the Structural Damping Ratio

The modal strain energy method (Equation (3)) or other rational analytical methods may be used to determine if the desired damping ratio has been achieved. At this stage, if the calculated damping ratio is lower than that of the design value, damper stiffness must be modified and another design cycle for determining the VE dampers' dimensions may begin.

Natural periods of the viscoelastically damped frame (VEDF) and SMRF are calculated to be 1.15 sec and 0.89 sec, respectively. The damping ratio calculated for the VEDF is estimated to be 15.2 %.

### 2.5 Perform Dynamic Analysis

Finally, dynamic analyses of the viscoelastically damped structure under the design earthquake should be conducted to ensure that all the design parameters have been conservatively satisfied.

## 3. Comparisons Between the Design Cases

### 3.1 Elastic Range

Following the analytical procedure described earlier, Figures 15a and 15b show the story drift and story shear envelopes of the two design cases calculated using time history analyses under the

compatible artificial earthquake scaled down by R. Also shown in the figure is the result carried out by the CQC (Kiureghian 1981) method. It can be seen that both the story drift and story shear are smaller for the case of VEDF. Both designs satisfy the drift requirement ( $< 0.36\%$ ) set by the building code. The CQC method gives very close results of the maximum story drift for the two design cases as compared to those predicted from time history analyses. The predicted story shears are also very close for the VEDF, and are a little conservative for the SMRF.

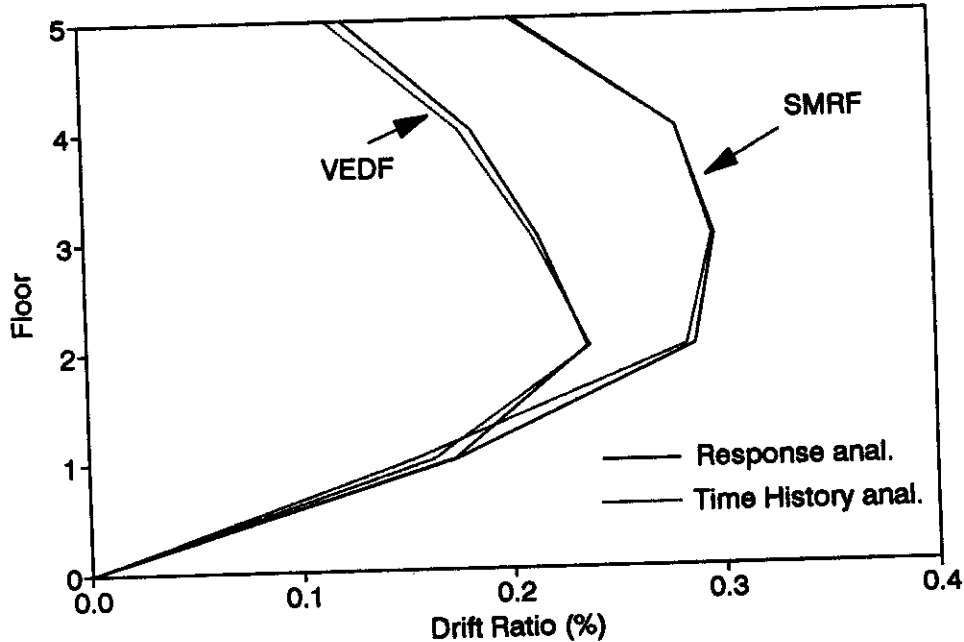

Fig. 15a Story drift envelope, 0.045g

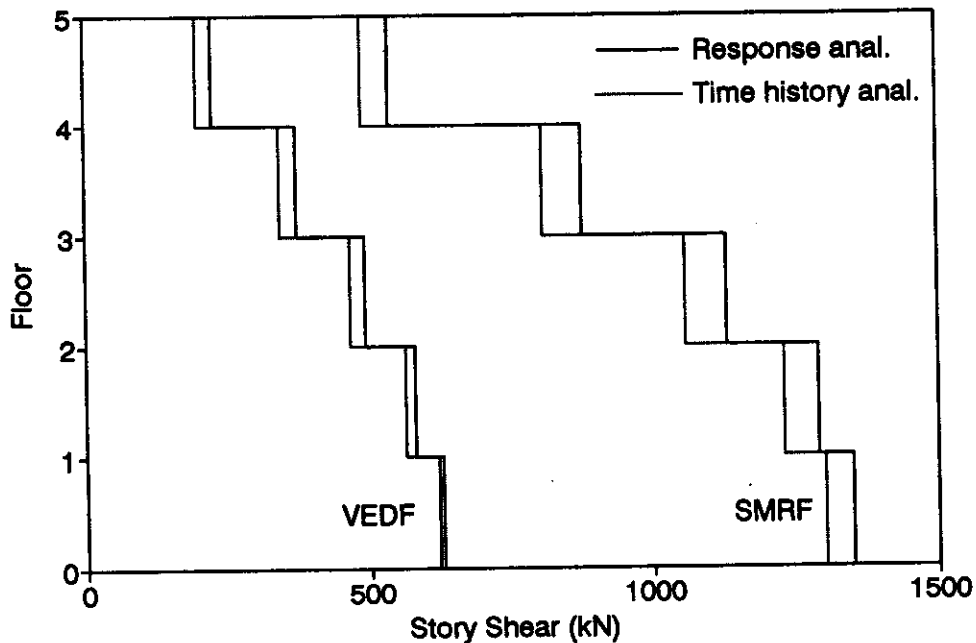
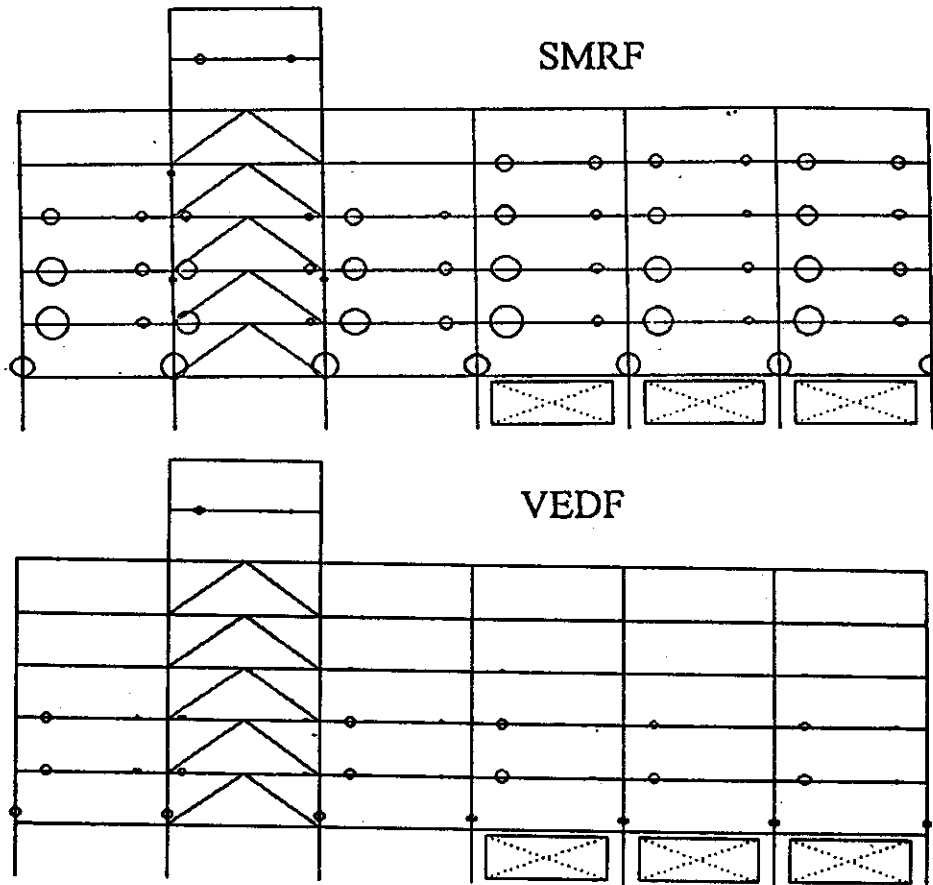

Fig. 15b Story shear envelope, 0.045g



**3.2 Inelastic Range**

Figure 16 shows the plastic hinge formation of the two design cases under the design earthquake of NEHRP (PGA = 0.36g). It can be seen that the plastic hinge rotations of the VEDF is much smaller than those of the SMRF. Similar results are obtained in story drift envelopes, as shown in Figure 17a.



**Fig. 16 Plastic hinge formation**

Figure 17b shows the accumulated story shear envelopes of the two structures. It can be seen that the maximum story shears experienced by the VEDF are also smaller than those of the SMRF. In addition, they dissipate seismic input energy differently (Uang and Bertero 1990). For the SMRF, most seismic input energy dissipated through inelastic deformation of the structural members (Figure 18a). It is therefore expected that severe structural and nonstructural damage may occur to this structure. For the VEDF, it can be seen that the inelastic hysteretic energy plays only a minor role in dissipating the seismic input energy (Figure 18b). Most of the input energy will be dissipated by the VE dampers and the primary frame may experience only minor yielding in this design earthquake. Figures 18c, d show a typical force deformation relationship and the expected temperature rise of the VE dampers, respectively, at the second floor of VEDF estimated by the previously mentioned simplified method.

From the above comparisons, it is clear that following the design regulations of NEHRP (1994), the viscoelastically damped structures can be designed conservatively as compared to the conventionally

designed structure. For economic consideration, the weight of structural members of the VEDF is about 25 % lighter than that of the SMRF.

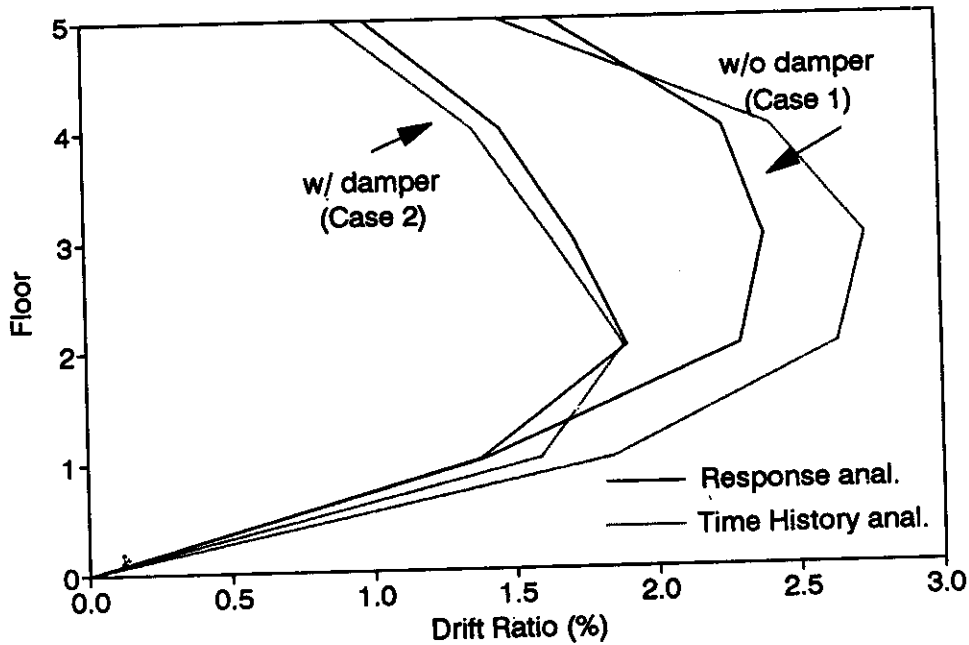

Fig. 17a Story drift envelope, 0.36g

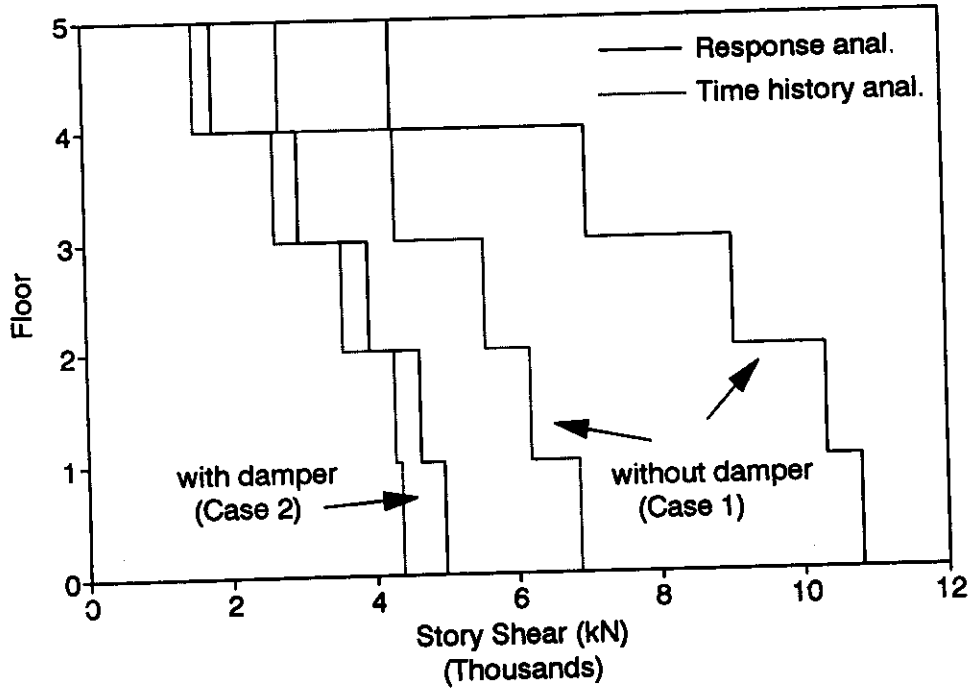

Fig. 17b Story shear envelope, 0.36g

**SEISMIC PERFORMANCE AT OTHER AMBIENT TEMPERATURE**

The VEDF described earlier was designed based on the ambient temperature of 30°C with 15 % damping ratio. For ambient temperatures other than 30°C, the structural damping ratio will be different. Using Equations(1) and (3), damping ratios of the VEDF under various design temperatures are shown in Figure 19. It can be seen that the structural damping ratio may change from about 36 % at 15°C to about

15 % at 30°C. Table 2 shows the envelopes of story drift, story shear, column axial force, column shear force, damper force and ductility demand, etc., of the VEDF under the 0.36g NEHRP compatible earthquake. The table shows that if ambient temperature is decreased, the story drift, story shear and column shear of VEDF will normally decrease due to increasing damper stiffness and damping. However, the VE damper force and the axial forces of the columns and damper braces may rise. Table 3 shows the demand/capacity ratio of the beams, columns and damper braces of VEDF under the design earthquake at both 15°C and 30°C. It can be seen that in general, with decreasing temperature, the demand/capacity ratios of the members become smaller except for the damper braces, which increase with decreasing temperature. As indicated in previous investigations, the ambient temperature should be carefully considered in the design of viscoelastically damped structures unless it is well controlled (Chang et al. 1992).

**Table 2: Envelopes for VEDF under NEHRP PGA=0.36g**

	Temperature °C	1F	2F	3F	4F	5F
story drift (%)	15	0.591	0.703	0.594	0.481	0.328
	22	0.944	1.029	1.031	0.834	0.544
	30	1.606	1.891	1.591	1.278	0.812
story shear (ton)	15	515	451	368	269	156
	22	462	429	351	256	149
	30	441	432	357	262	151
column axial force (ton)	15	595	403	288	169	81
	22	489	336	254	157	81
	30	410	302	225	146	81
max. column shear force (ton)	15	36.3	39.6	35	27.7	26.7
	22	35.3	29.9	28.9	20.8	22.9
	30	30.4	21.4	21.6	15.4	20.1
damper force (ton)	15	298	335	268	204	123
	22	174	217	181	143	88
	30	119	139	116	92	57
ductility ( $\Delta_{0.36g} / \Delta_y$ )	15	1.17				
	22	1.50				
	30	1.75				

**Table 3a: Beam Strength Check (at Critical Section) (NEHRP 0.36g)**

Group Name	Floor Level	Section	M <sub>capacity</sub> (t-m)	M <sub>demand</sub> /M <sub>capacity</sub>		
				15°C	22°C	30°C
Interior Beam	1-3	W14x109	146	0.54	0.69	0.71
	4-5	W14x109	146	0.40	0.48	0.59
Exterior Beam	1-3	W14x61	78	0.52	0.69	0.70
	4-5	W14x43	53	0.48	0.60	0.69

$$M_{capacity} = Z F_y$$

**Table 3b: Column Strength Check (at critical section) (NEHRP 0.36g)**

Group Name	Floor Level	Section	(2)		
			15°C	22°C	30°C
Interior Column	1-3	35x35x2.3x2.3	0.69	0.93	0.95
	4-5	35x35x1.5x1.5	0.32	0.54	0.82
Exterior Column	1-3	35x35x1.5x1.5	0.52	0.72	0.93
	4-5	35x35x1.0x1.0	0.64	0.70	0.88

$$\frac{P_u}{\phi_c P_n} + \frac{8}{9} \frac{M_u}{\phi_b M_n} \leq 1.0$$

**Table 3c: Brace Stability Check (NEHRP 0.36g)**

	15°C	20°C	30°C
$P_{max}$	206	134	85
$P_{max}/P_{cr}$	0.97	0.63	0.4

$$P_{cr} = \frac{\pi^2 EI}{(kl)^2} = 213$$

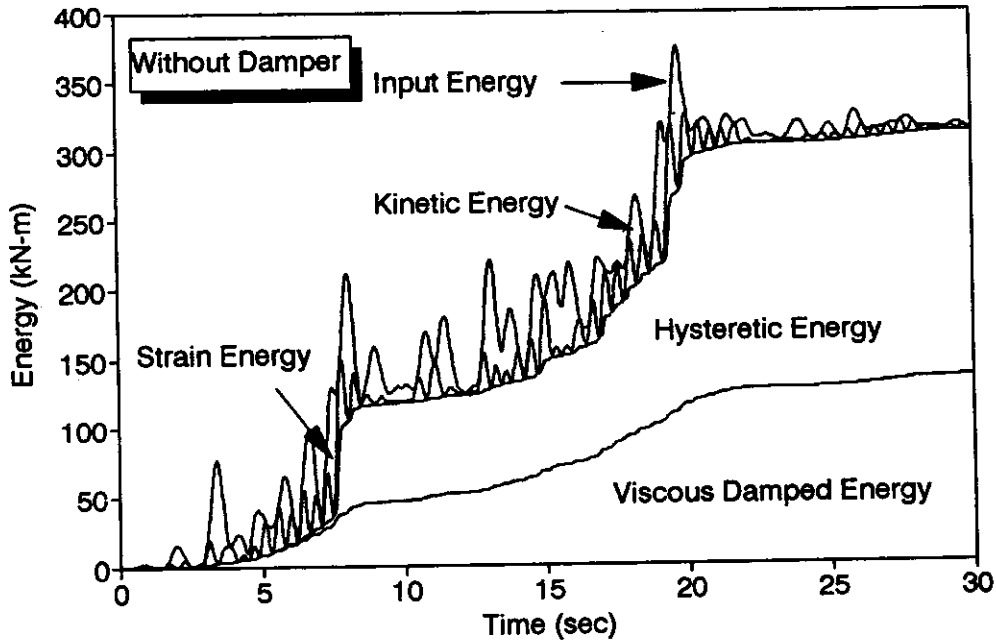

Fig. 18a Input energy distribution, without damper

**SEISMIC PERFORMANCE UNDER OTHER MAJOR EARTHQUAKE**

Seismic safety of the above two design cases are evaluated using six recent major earthquakes: Newhall90, Newhall360, Sylmar90 and Sylmar360 of the Northridge earthquake (Darragh et al. 1994) and the 1995 Kobe-NST and Kobe-EWT of the Hyogoken-Nanbu earthquake (Architectural Institute of Japan, 1995). Table 4 summarizes the maximum lateral displacement, drift ratio, base shear and energy dissipation ratio of the VEDF at 30°C and SMRF under these earthquakes.

**Table 4: Maximum Response (under Full-Scale Earthquake)**

	Max. Displacement (cm)		Max. Drift Ratio (%)		Max. Base Shear (ton)		Plastic Energy (%)		Damping Energy (%)	
	SMRF	VEDF	SMRF	VEDF	SMRF	VEDF	SMRF	VEDF	SMRF	VEDF
SYL90	26.3	18.5	2.14	1.47	646.4	347.4	52.5	2.3	47.5	97.7
SYL360	21.3	27.1	1.77	2.27	761.5	483.2	56.7	18.4	43.3	81.6
NEW90	23.8	17.9	1.90	1.48	579.4	350.8	38.7	6.2	61.3	93.8
NEW360	36.8	29.7	2.93	2.43	657.6	481.5	64.3	13.6	35.7	86.4
KOBEWT	29.7	20.9	2.39	1.61	669.9	373.2	61.6	0	38.4	100
KOBNST	33.3	27.0	2.67	2.17	710.5	451.8	64.6	9.1	35.4	90.9

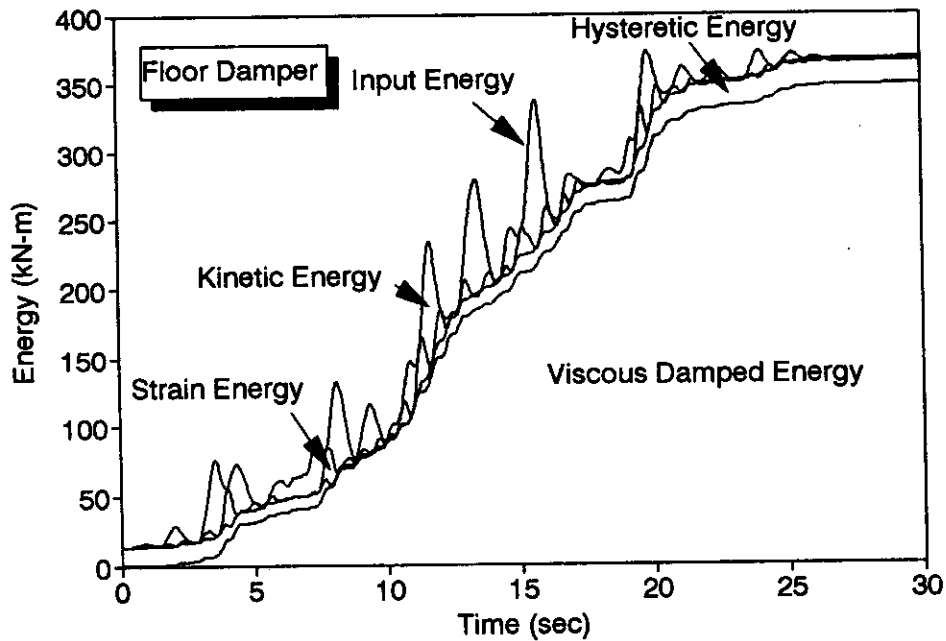

Fig. 18b Input energy distribution, floor damper

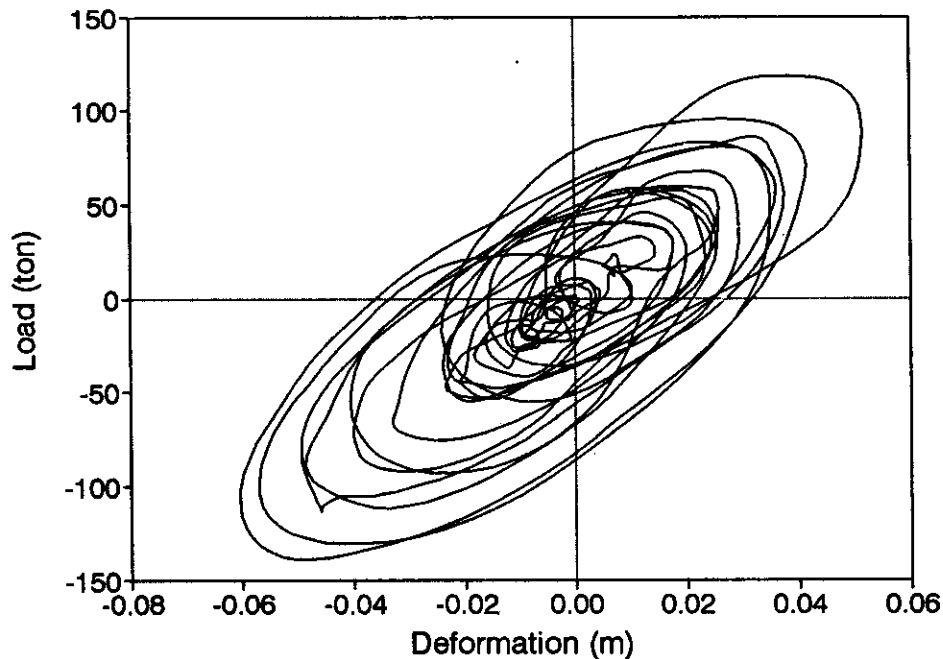

Fig. 18c Damper load-deformation curve

**SUMMARY AND CONCLUSIONS**

A summary on the experimental and analytical study of VE dampers as energy dissipation devices in seismic structural applications is first described. It is concluded that VE dampers are effective in reducing seismic vibrations and ductility demand of structures. Analytical studies show that the modal strain energy method can be used to reliably predict the equivalent structural damping of the structure and that the seismic response of the viscoelastically damped structure can be accurately simulated by

conventional modal analysis techniques. Based on these studies, the modal strain energy method has been incorporated into the computer programs ETABS and DRAIN2D+ for seismic analysis and design of structures with added VE dampers.

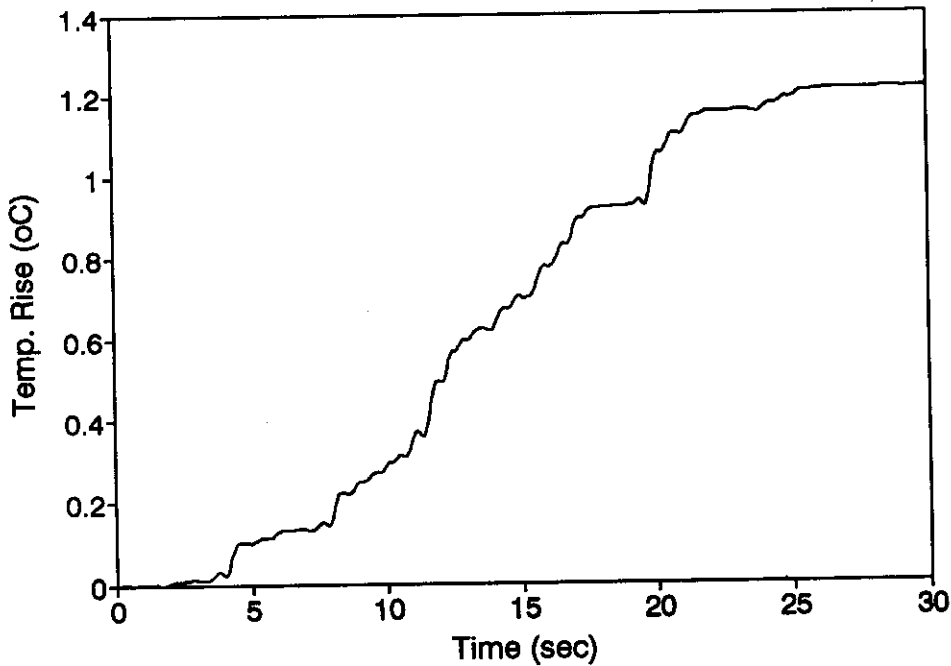

Fig. 18d Temperature rise of viscoelastic damper

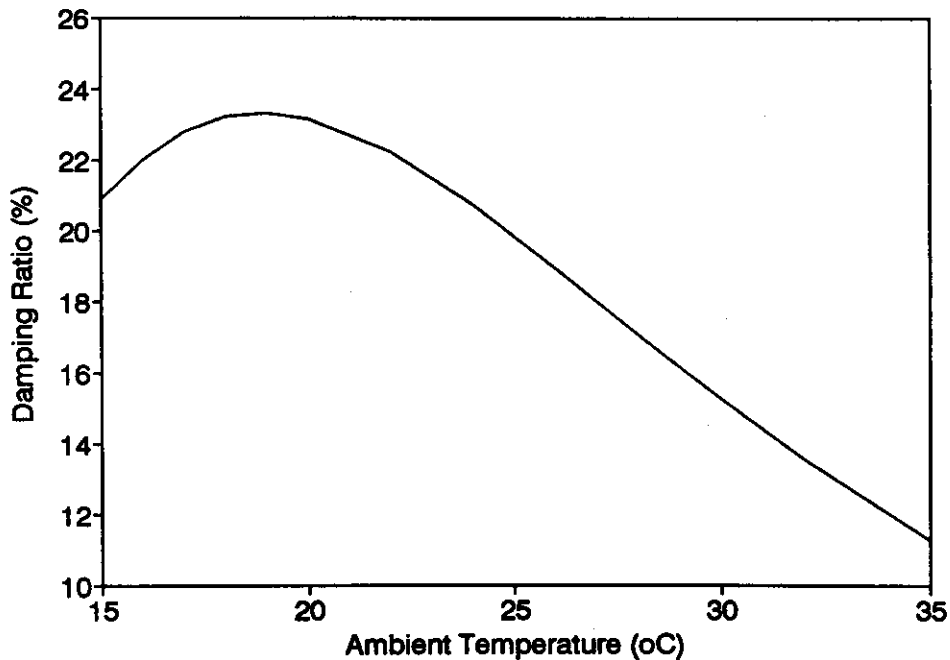

Fig. 19 Temperature effect on damping

A design procedure for seismic retrofit and for new design of structures with added viscoelastic dampers has been developed. An example is presented to illustrate the design procedure for viscoelastically damped structures and to compare the safety and economy with a conventionally designed special moment resisting structure. It is found that the seismic resistant capacity of the viscoelastically damped structure is better than that of the conventionally designed one. The design

procedure presented in this paper may also provide a safe and economic solution for the design of viscoelastically damped structure under the current seismic design regulations.

Results from this study suggest that it is possible to design a structure which remains elastic or experience only minor yielding under strong earthquake ground motions if VE dampers are used to provide the structure with sufficiently large damping at a specified design temperature. Based on this study and the results from previous investigations, a design damping ratio of 15 % is recommended. The design and analysis procedures for viscoelastically damped structures can be readily applied for practical applications.

#### ACKNOWLEDGEMENTS

This research has been supported by the National Science Council of Taiwan, R.O.C. (NSC87-2621-P-002-026). The support is gratefully acknowledged.

#### REFERENCES

1. ATC 17-1 (1993). "Proceedings of Seminar on Seismic Isolation, Passive Energy Dissipation, and Active Control," Applied Technology Council, Redwood City, California.
2. Aiken, I.D. and Kelly, J.M. (1990). "Earthquake Simulator Testing and Analytical Studies of Two Energy-Absorbing System for Multistory Structures," Report No. UCB/EERC-90/03, University of California at Berkeley.
3. Architectural Institute of Japan (1995). "Preliminary Reconnaissance Report of the 1995 Hyogoken-Nambu Earthquake."
4. Bergman, D.M. and Hansen, R.D. (1993). "Viscoelastic Mechanical Damping Devices Tested at Real Earthquake Displacements," *Earthquake Spectra*, Vol. 9, No. 3, pp. 389-417.
5. Chang, K.C., Soong, T.T., Oh, S.T. and Lai, M.L. (1992). "Effect of Ambient Temperature on Viscoelastically Structures," *Journal of Structural Engineering*, ASCE, Vol. 118, No. 7, pp. 1955-1973.
6. Chang, K.C., Soong, T.T., Lai, M.L. and Nielson, E.J. (1993). "Viscoelastic Dampers as Energy Dissipation Devices for Seismic Applications," *Earthquake Spectra*, Vol. 9, No. 3, pp. 371-387.
7. Chang, K.C., Soong, T.T., Oh, S.T. and Lai, M.L. (1995). "Seismic Behavior of Steel Frame with Added Viscoelastic Dampers," *Journal of Structural Engineering*, ASCE, Vol. 121, No. 10, pp. 1418-1426.
8. Chang, K.C. Chen S.J. and Lai, M.L. (1996). "Inelastic Behavior of Steel Frames with Added Viscoelastic Dampers," *Journal of Structural Engineering*, ASCE, Vol. 122, No. 10, pp.1178-1186.
9. Chang, K.C., Tsai, M.H., Chang, Y.H. and Lai, M.L. (1998). "Temperature Rise effect of Viscoelastically Damped Structures under Strong Earthquake Ground Motions," *The Chinese Journal of Mechanics*, Vol. 14, No. 3, pp. 125-136.
10. Darragh, R., Cao, T., Cramer, C., Huang, M. and Shakal, A. (1994). "Processed CSMIP Strong-Motion Records from The Northridge, California Earthquake of January 17, 1994: Release No. 1, Report No. OSMS 94-0613, California Strong Motion Instrumental Program, California Department of Conservation Division of Mines and Geology, Sacramento, California.
11. EERI (1993). "Earthquake Spectra," Oakland, California.
12. Johnson, C.D. and Kienholz, D.A. (1982). "Finite Element Prediction of Damping in Structures with Constrained Viscoelastic layers," *AIAA Journal*, Vol. 20, No. 9, pp.1284-1290.
13. Kasai, K., Munshi, J.A., Lai, M.L. and Maison, B.F. (1993). "Viscoelastic Dampers Hysteretic Modal: Theory, Experiment, and Application," *Proceedings of ATC-17-1 Seminar on Seismic Isolation, Passive Energy Dissipation, and Active Control*, Vol. 2, pp. 521-532.
14. Kiureghian, A.D. (1981): "A Response Spectrum Method for Random Vibration Analysis of MDF Systems," *Journal of Earthquake Engineering and Structural Dynamics*, Vol. 9, pp. 419-435.

15. Lai, M.L., Chang, K.C., Soong, T.T., Hao, D.S. and Yeh, Y.C. (1995). "Full-Scale Viscoelastically Damped Steel Frame," *Journal of Structural Engineering, ASCE*, Vol. 121, No. 10, pp. 1443-1447.
16. Mahmoodi, P. (1969). "Structure Dampers," *Journal of Structural Engineering, ASCE*, Vol. 95, No. 10, pp. 1661-1672.
17. NEHRP (1994). "Recommended Provisions for the Development of Seismic Regulations for New Buildings," Federal Emergency Management Agency, Building Seismic Safety Council, Washington, D.C.
18. Shen, K.L. and Soong, T.T. (1995). "Modeling of Viscoelastic Dampers for Structural Application," *Journal Engineering Mechanics, ASCE*, Vol. 121, No. 6, pp. 694-701.
19. Shen, K.L., Soong, T.T., Chang, K.C. and Lai, M.L. (1995). "Seismic Behavior of a 1/3 Scale RC Frame with Added Viscoelastic Dampers," *Engineering Structures*, Vol. 17, No. 5, pp. 372-380.
20. Tsai, K.C. and Li, J.W. (1994). "DRAIN2D+ : A General Purpose Computer Program for Static and Dynamic Analysis of Inelastic 2D Structures," supplemented with a graphic processor "VIEW 2D, User's Guide," Report No.CEER/R83-03, Center for Earthquake Engineering Research, National Taiwan University.
21. Uang, C.M. and Bertero, V.V., (1990). "Evaluation of Seismic Energy in Structures," *Earthquake Engineering and Structural Dynamics*, Vol. 19, pp. 77-90.
22. Uang, C.M. (1991). "Establishing R (or  $R_w$ ) and  $C_d$  Factors for Building Seismic Provision," *Journal of Structural Engineering, ASCE*, Vol. 117, No. 1, pp. 19-28.
23. Wilson, E.J. Hollings, J.P. and Dovey, H.H. (1979). "ETABS -Three Dimensional Analysis of Building Systems (Extended Version)," EERC Report 75-13, University of California, Berkeley, April 1975, Revised March 1979.
24. Zambrano A., Inaudi, J.A. and Kelly J. (1996). "Modal Coupling and Accuracy of Modal Strain Energy Method," *Journal of Engineering Mechanics, ASCE*, Vol. 122, No. 7, pp. 603-612.
25. Zhang, R.H. and Soong, T.T. (1992). "Seismic Design of Viscoelastic Dampers for Structural Applications," *Journal of Structural Engineering, ASCE*, Vol. 118, No. 5, pp. 1375-1392.